

RADIO CONTROLLED 10 ENGINE POWERED 4WD RALLY CAR

# FORD RS-200

- EPOCH MAKING GAS ENGINE POWERED CAR, EASY TO HANDLE MORE THAN ELECTRIC CAR.
- SHAFT DRIVE 4WD RALLY CAR, CAPABLE TO GO EITHER ON-ROAD AND OFF-ROAD.
- EQUIPPED WITH OS 10FP-BK ENGINE WITH RECOIL STARTER AS STANDARD.
- DOUBLE WISH BONE FOUR WHEEL INDEPENDENT SUSPENSION SYSTEM WITH NEW OIL SHOCKS.
- SEMI-READY-TO RUN CAR KIT WITH ENGINE AND DRIVE SYSTEM ASSEMBLED IN THE FACTORY.
- KIT INCLUDES SPECIAL MUFFLER, FUEL TANK, PLUG HEATING BOX (SIZE OF 4D-SIZE DRY CELLS).
- FUEL AND 2 CH RADIO ARE NOT INCLUDED.

1:10 SCALE



**KYOSHO**  
THE FINEST RADIO CONTROL MODELS

KIT NO. 3013

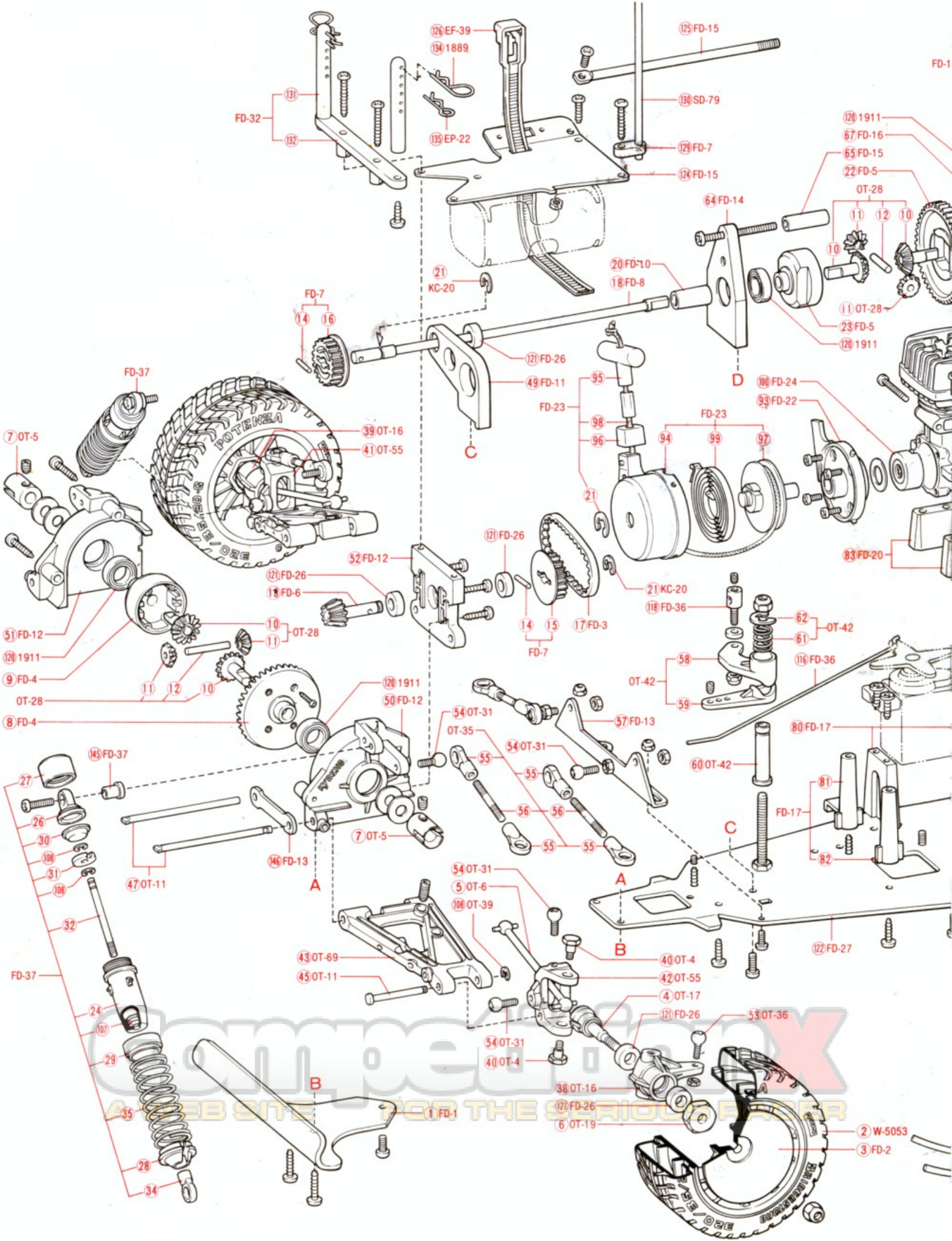

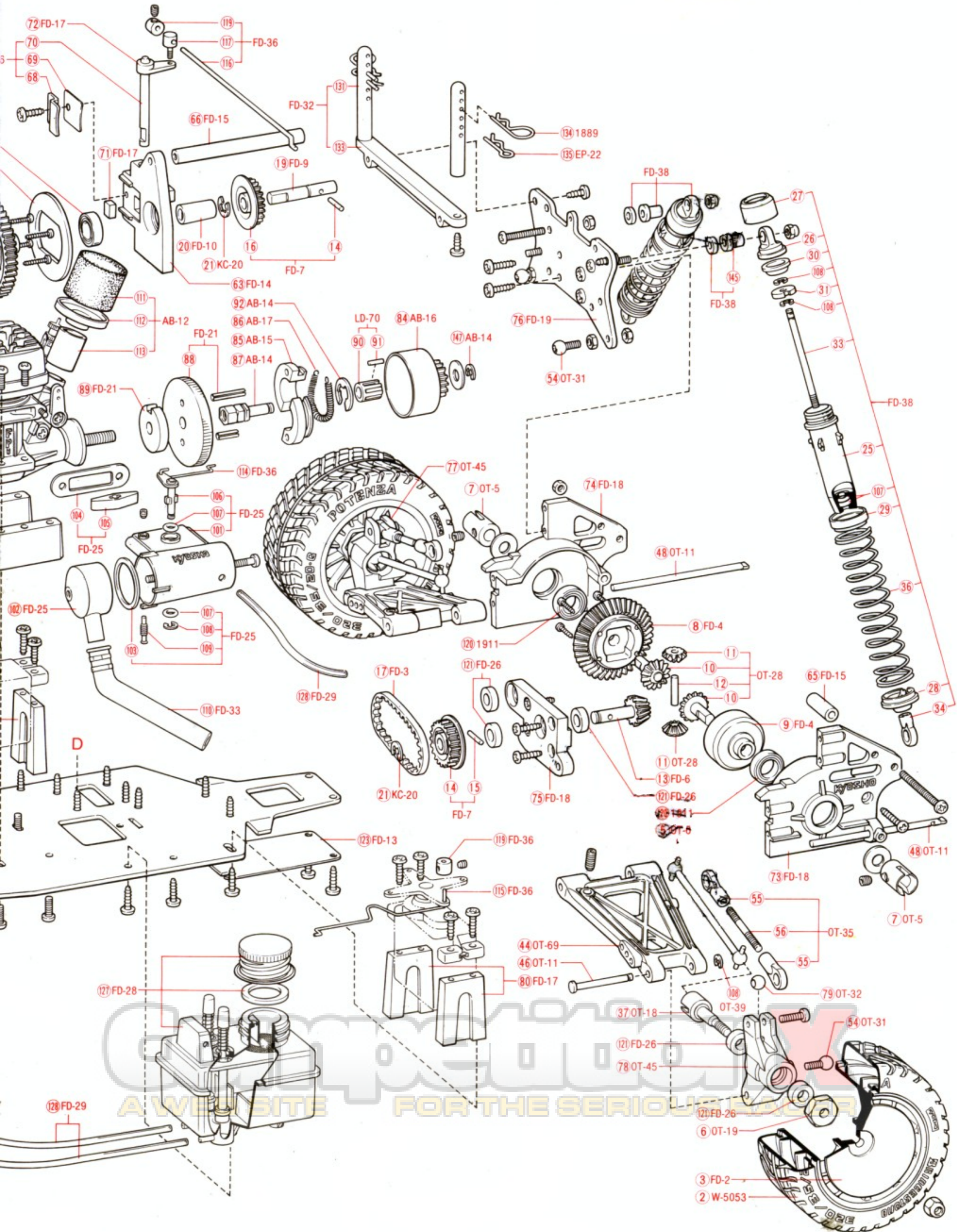

BEFORE ASSEMBLY

\*Read the instruction carefully.

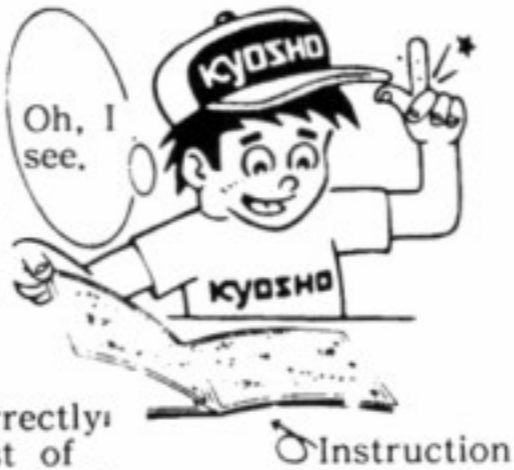

You can assemble the kit more easily if you have grasped the general idea of steps and structure beforehand by reading it through to the end.

\*Check the parts in the kit. Check to see if all the parts are correctly bagged as they are listed in the "List of Bagged Parts". Your thorough understanding of the assembly prior to starting will enable you to build the kit without difficulty.



Any claims for replacements or refunds for the model in the process of assembly will not be accepted without shortage or inferiority of the parts.

\*Learn on the marks described in the instruction.

**SW CEMENT** ... locktite.  
(It will prevent the screws and nuts get loosen by vibration while running.)

**GREASE** ... be applied.  
(It will reduce friction to assure smooth movements.)



\*Be well aware of the different types of screws.  
1. The difference between the TP screw (short form of self-tapping screw) and the ordinary screw is...

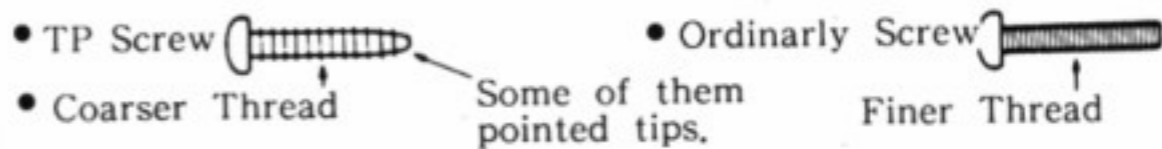

2. The kinds of screws which will be used in this instruction.

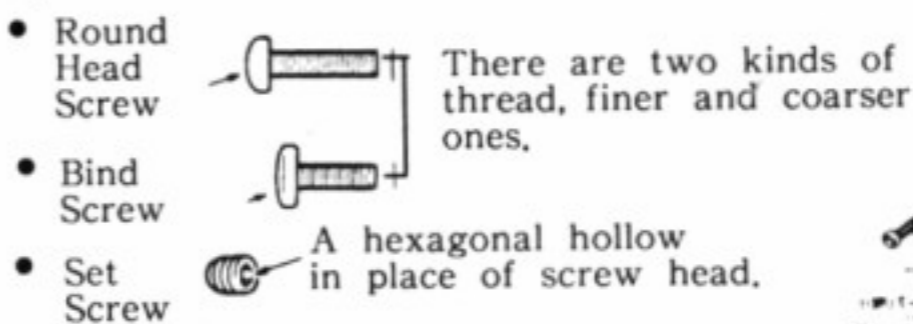

\*Pick up the correct parts and screw. Compare the shape and size of small parts, such as screws, nuts, and washers with the attached sheet of "List of Small Parts".



\*Be sure about the location and direction of parts to install.

Double-check the location and orientation of parts with the illustration before installation. When necessary, assemble the parts themselves tentatively before proceeding to the next step.



\*Do not tighten the TP screw too strong. Do not use excessive force when tightening the TP screws, or you may strip the thread in the plastic. It is recommended to stop tightening it when the thread part on the screw goes into the plastic part and you feel some resistance from the tightening.

Over tighten may strip the thread in the plastic.

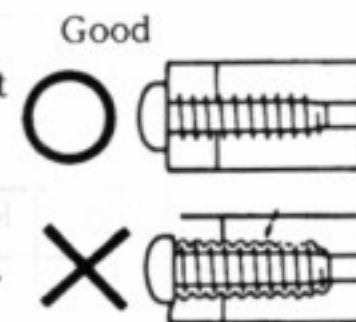

THINGS NEED BESIDES THE KIT

[2 Channel Radio System]

Two types of radio control set are on the market, the stick type and the steering wheel type choose which ever you like.

Transmitter



Servo

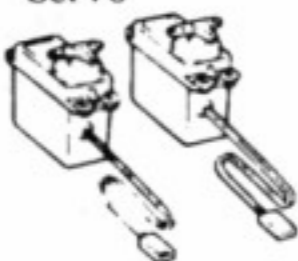

Receiver



Switch



[Battery for Radio System]

AA Size Battery for Transmitter ...8 pcs.



[Articles Required Running]

• These are included with the kit.

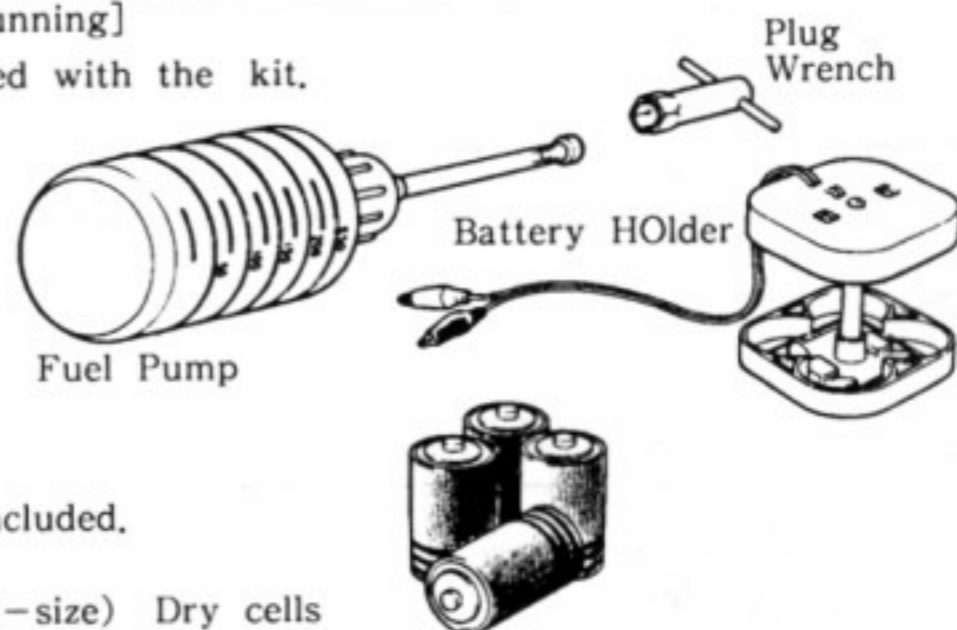

• These are not included.

(1) 4 Unit #1 (D-size) Dry cells

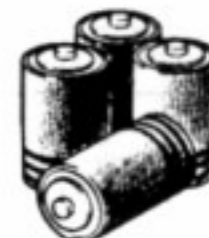

(2) Glow Fuel

\*Gasoline or kerosene cannot be used.

[Required Tools] Hex Key, Grease & CW cement are included with the kit.

Philips Screw Driver (L, S)  
Slot Screw Driver (M)

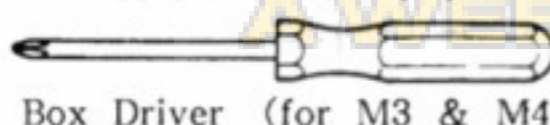

Box Driver (for M3 & M4 Nut)

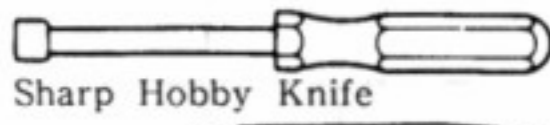

Sharp Hobby Knife

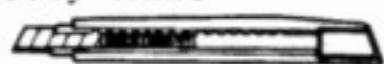

Needle Nose Plier



Round Cutter

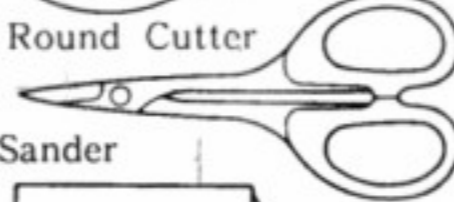

Sander



Awl

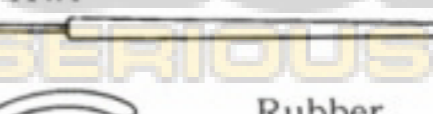

Wire Cutter

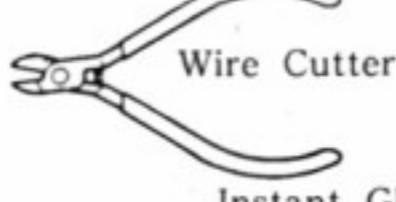

Instant Glue



Polyca Paint

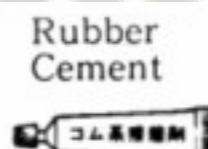

Brush



Micron Line Tape



LIST OF BAGGED PARTS "FORD RS-200"

Bag	Key #	Parts Name	Q'ty	Step
Blister	Assembly	Chassis Assembly	1	4
FRS-1 Shock Parts (For Front)	24	Front Shock Case	2	1
	26	Shock Cap	2	2
	27	Shock Ring	2	2
	28	Spring Holder	2	2
	29	Spring Spacer	2	2
	30	Pressure Top	2	2
	31	Shock Piston	2	1
	32	Front Shock Shaft	2	1
	34	Shock End	2	1
	35	Front Shock Spring	2	2
	108	E Ring (E-2.5)	4	1
	139	Shock Oil	1	2
	145	Shock Bush	2	7
FRS-2 Shock Parts (For Rear)	25	Rear Shock Case	2	1
	26	Shock Cap	2	2
	27	Shock Ring	2	2
	28	Spring Holder	2	2
	29	Spring Spacer	2	2
	30	Pressure Top	2	2
	31	Shock Piston	2	1
	33	Rear Shock Shaft	2	1
	34	Shock End	2	1
	36	Rear Shock Spring	2	2
108	E Ring (E-2.5)	4	2	
145	Shock Bush	2	1	
FRS-4	4	Front Wheel Shaft	2	3
	5	Swing Shaft	4	6 10
	6	Drive Washer	4	7
	7	Joint Cap	4	4 9
	37	Rear Wheel Shaft	2	3
	38	Knuckle Arm (R)	1	3
	39	Knuckle Arm (L)	1	3
	40	King Pin	4	3
	121	5 φ x10 Plane Bearing	8	3 3
FRS-5	45	Sus. Shaft (A) (Silver)	2	4
	46	Sus. Shaft (B) (Black)	2	4
	47	Sus. Shaft (C)	2	4
	48	Sus. Shaft (D)	2	4
	53	M2.6 Pillow Ball (Black)	2	3
	54	M3 Pillow Ball (Silver)	12	4 6 9 10
	56	Ball End Rod	6	5
	79	5.8 φ Ball	2	5
146	Front Sus. Plate	1	3	
FRS-6	41	Front Hub (R)	1	3
	42	Front Hub (L)	1	3
	43	Front Sus. Arm	2	4
	44	Rear Sus. Arm	2	3
	55	Ball End	12	5
	65	Joint Collar (Short)	1	9
	77	Rear Hub (L)	1	3

Bag	Key #	Parts Name	Q'ty	Step
FRS-6	78	Rear Hub (R)	1	3
	80	Servo Mount	4	3
	131	Servo Mount (A)	4	2
	132	Servo Mount (B)	1	2
	133	Servo Mount (C)	1	2
FRS-7	110	Tail Pipe	1	10
	111	Air Filter Element	1	P.13
	112	Element Holder	1	*
	113	Adaptor Pipe	1	*
	115	Throttle Rod	1	10
	116	Linkage Rod	2	14 16
	117	2 φ Linkage Guide	1	10
	118	3 φ Linkage Guide	1	14
	119	Rod Stopper	2	16
	126	Strap	1	14
	130	Antenna	1	14
	136	Plug Wrench	1	P.13
	140	Battery Holder	1組	P.12
	141	Battery Holder collar	2	
FPS-8	3	Wheel	4	7
Others	2	Tire	4	7
	137	Body	1	18
	138	Fuel Pump	1	P.12
	142	Decal	1	20
		Instruction	1	
FRS-3 Screw, Nuts & Others	108	E Ring (E-2.5)	5	1 2
	134	Body Pin	4	2
	135	Hook Pin	4	2
	143	Hex Key (1.5)	1	10 10
	144	Hex Key (2)	1	4 9
		Flat Head Screw M3 X12	5	
		• M3 X20	2	
		• M3 X30	1	
		• M4 X55	1	
		TP Bind Screw M3 X10	20	
		TP Round Head Screw M3 X18	2	
		Nut M2.6	2	
		• M3	11	
		• M4	1	
		Nylon Nut M3	3	
		• M4	4	
		Set Screw M4 X8	4	
	• M4 X4	4		
	• M3 X3	3		
	Flat Washer M5	6		

# 1 ASSEMBLY OF OIL SHOCK

The parts for the front shocks are contained in the bag "FRS-1", and those for the rear shocks in "FRS-2".

(FRS-) after a part name indicates the header number of a bag which contains the part. Do not discard the header, but put it in the bag or tape it down for easier identification of the part.

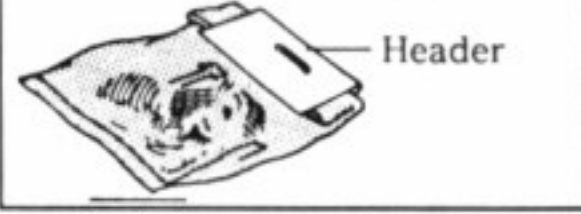

Stage 1

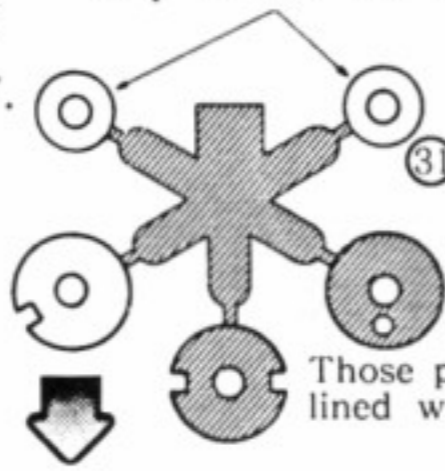

Remove any flash with a knife and smooth the surface.

Stage 2

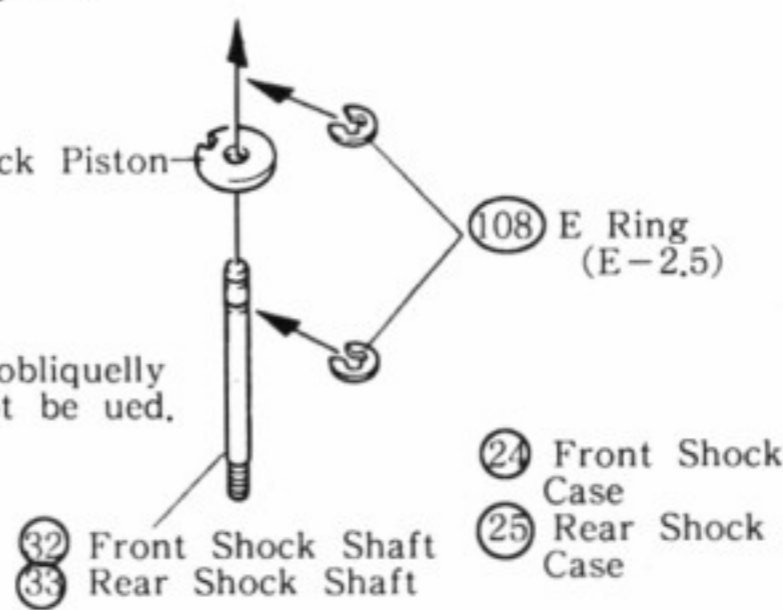

Assemble two each of this for the front and the rear.

Stage 3

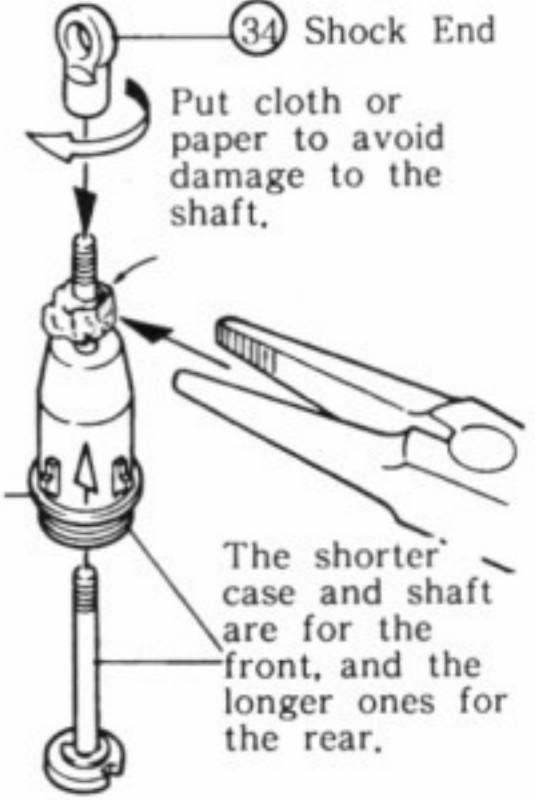

Put cloth or paper to avoid damage to the shaft.

The shorter case and shaft are for the front, and the longer ones for the rear.

# 2 FILLING THE SHOCK OIL

Stage 1

Place the piston to the bottom and pour oil little by little. Move the piston up and down gently to get rid of air bubbles.

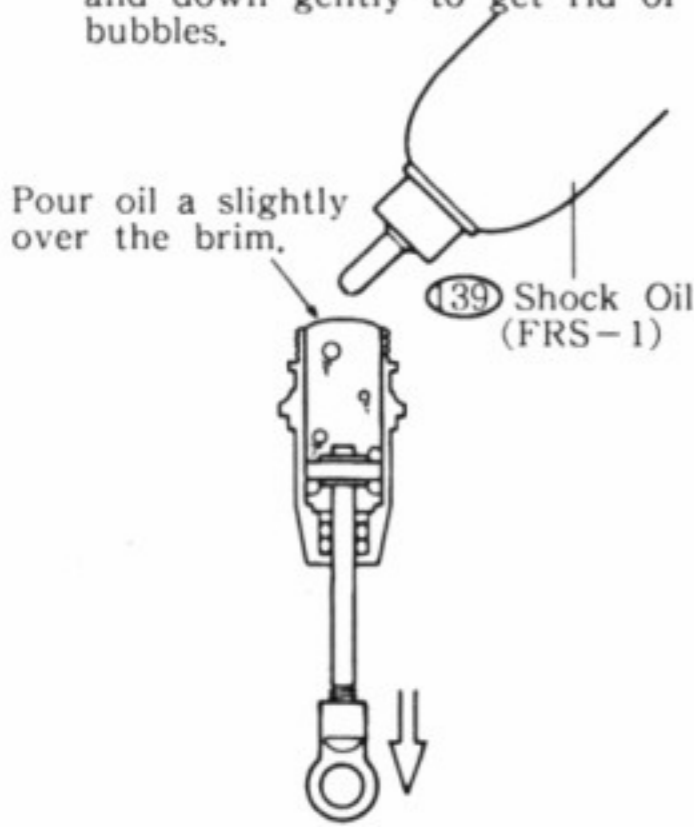

Stage 2

Push down the piston all the way and tighten the shock head slowly. At this time excessive oil will flow out.

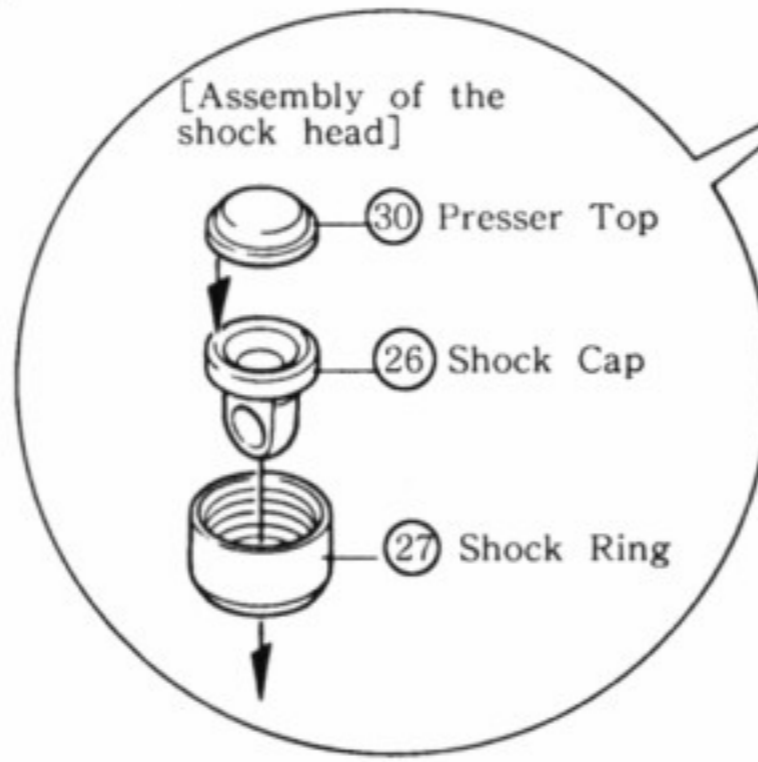

Tighten the head firmly so that the oil will not leak out.

Stage 3

Move the piston up and down to see if it will operate smoothly.

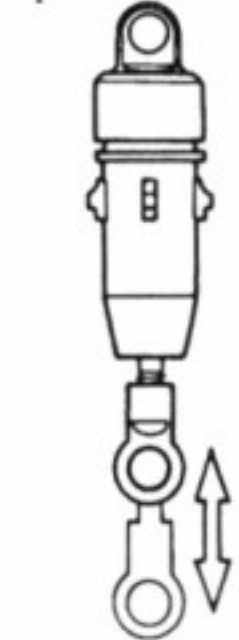

It should slide smoothly.

For setting up the shock spring with less tension, do not put the spring spacer.

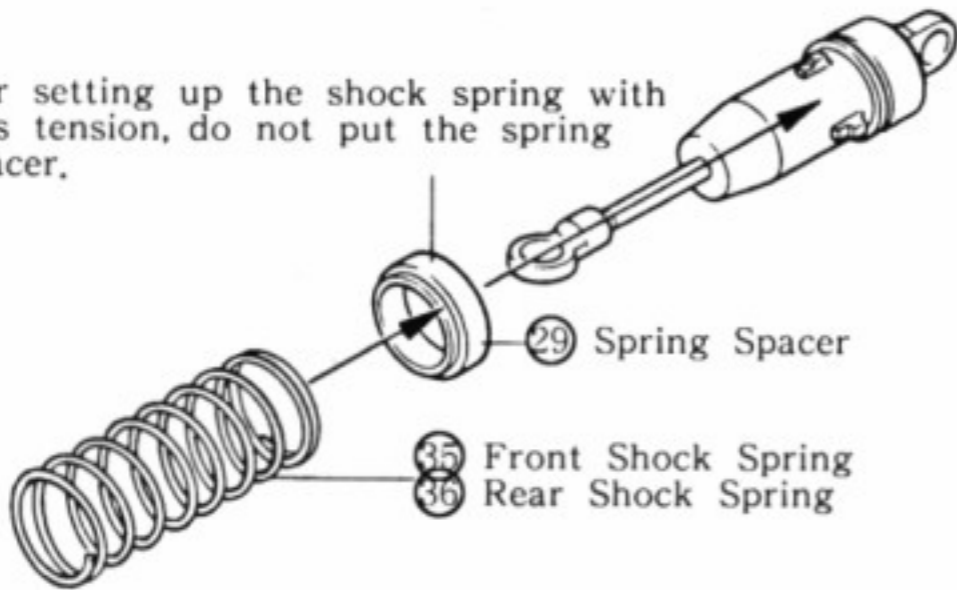

Stage 4

Attach the rest of parts, then the shock will be completed.

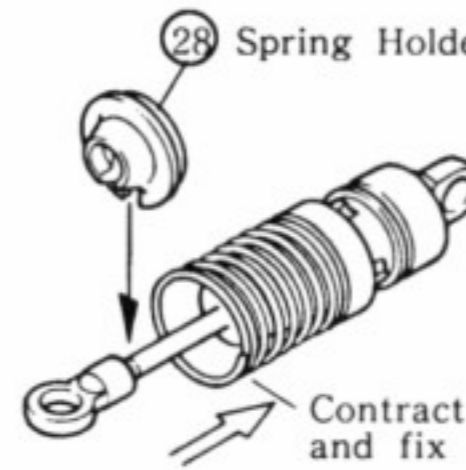

Contract the spring and fix it in position.

The front shocks will be installed in step 7, and the rear shocks in step 11.

# 3 ASSEMBLY OF KNUCKLE ARM

Watch the marks "R" and "L", and the orientation.

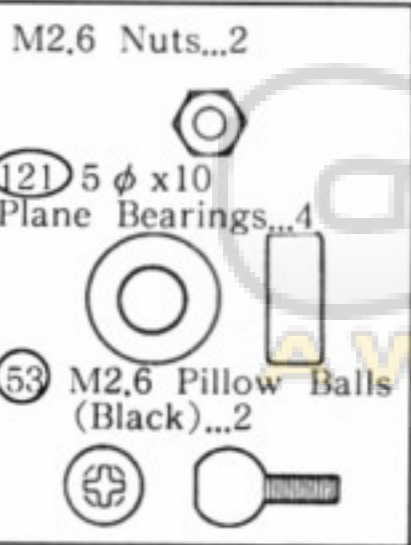

Stage 1 [Right]

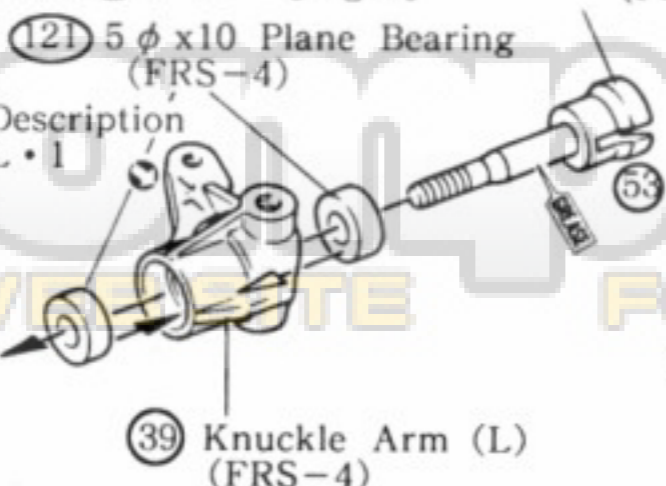

Stage 2

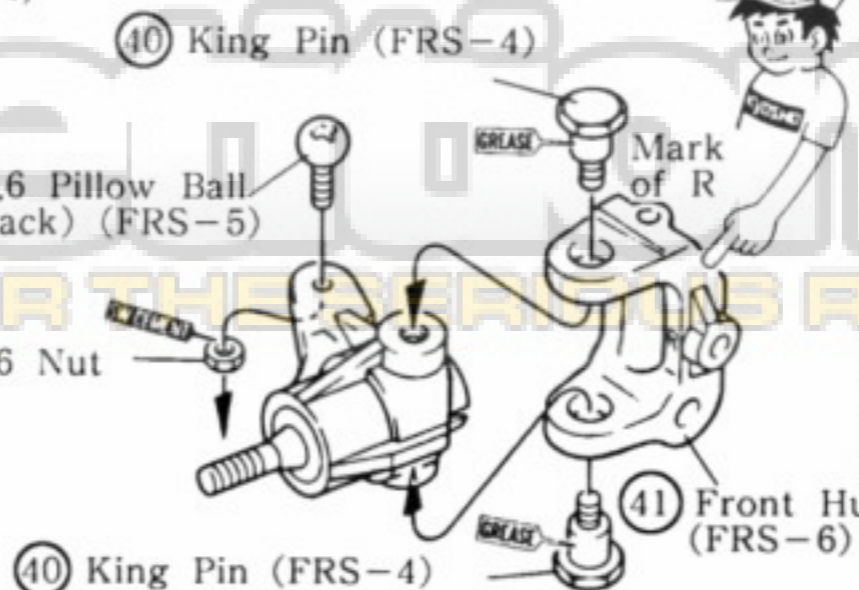

Stage 3 [Left]

Knuckle Arm (R) (FRS-4)

Description R • 2

Description L • 1

Front Hub (L) (FRS-6)

Assemble this in the same way as was done with the right side counterpart.

## 4 INSTALLATION OF FRONT SUSPENSION ARM

- M4x4 Set Screws...2
  - M4x8 Set Screws...2
  - M5 Washers...4
  - ④7 Suspension Shafts (C)...2
- 

### Stage 1

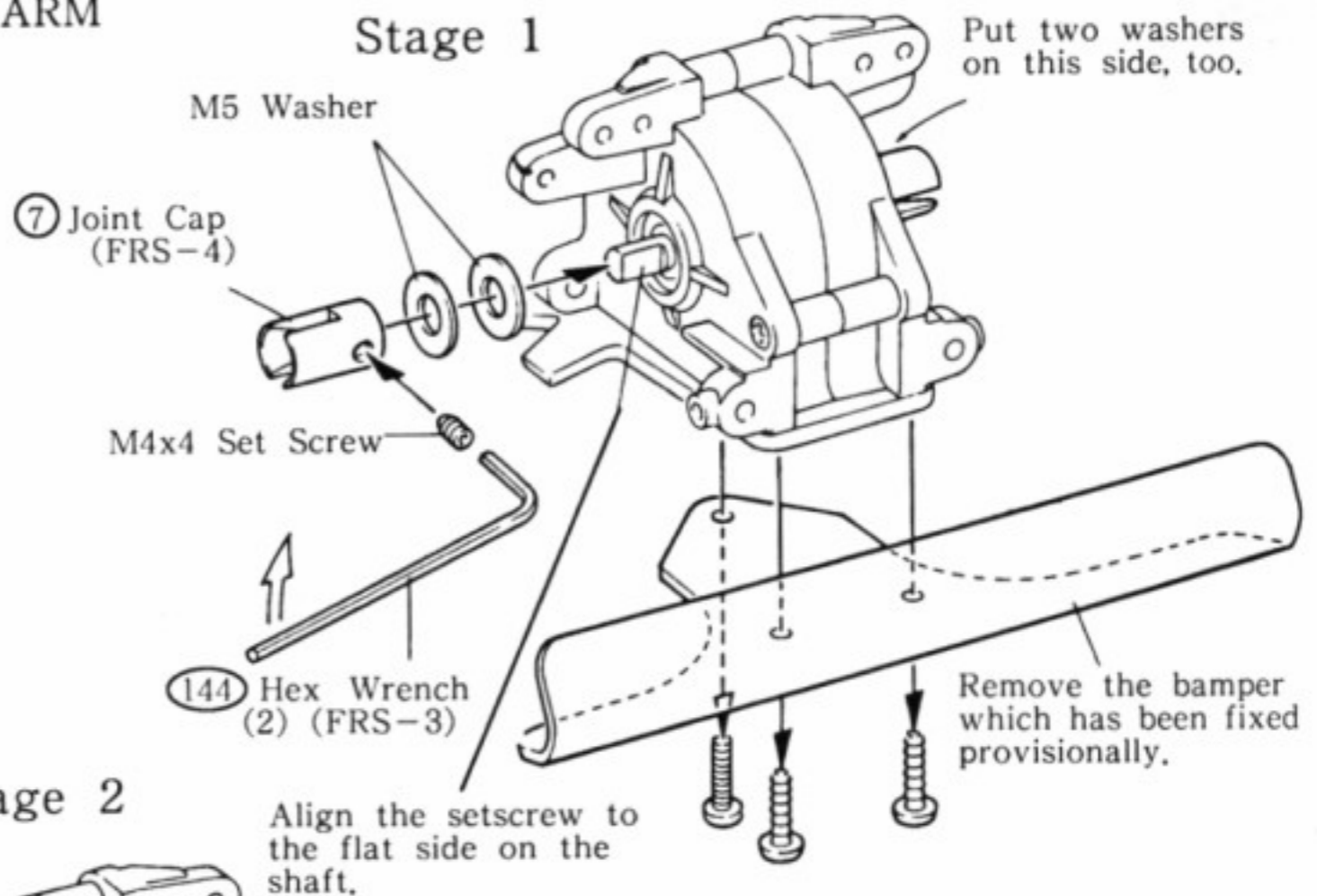

This is the screw to adjust the car clearance. By screwing in, you will have less clearance, and the other way more body clearance.

### Stage 2

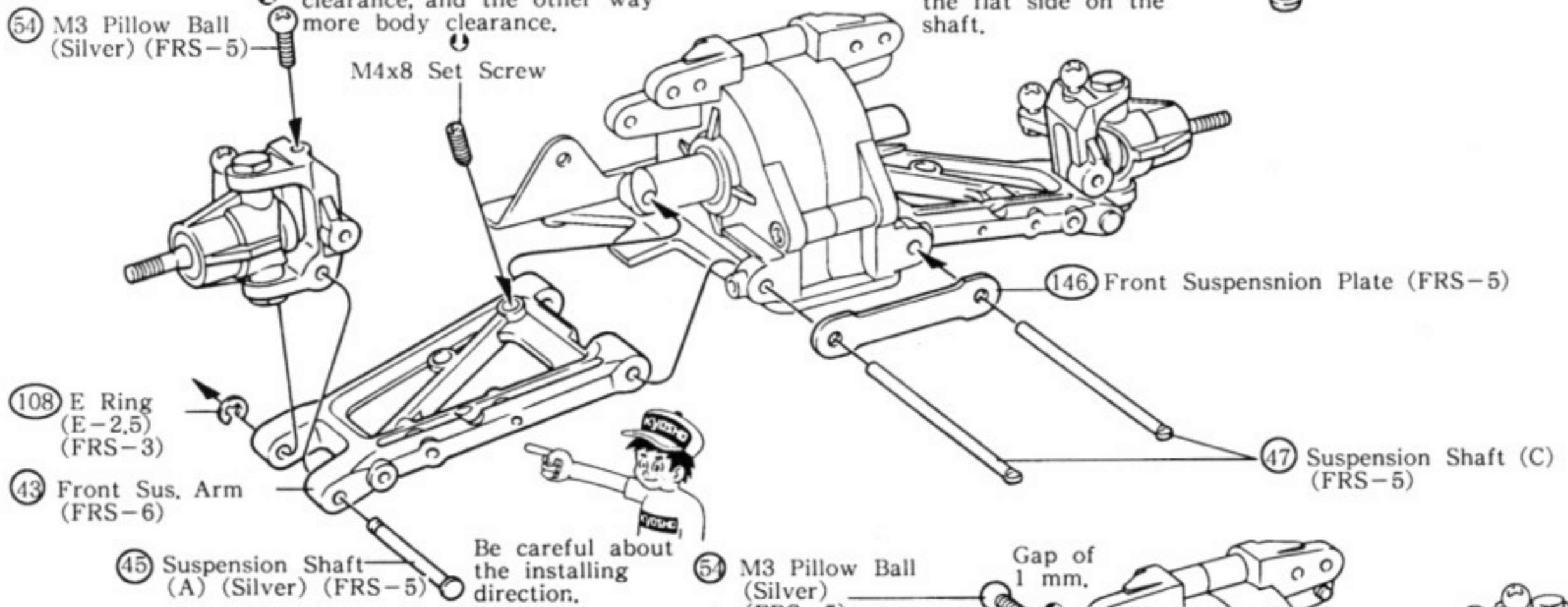

When fixing a M3 pillow ball into a plastic part,

- M3 Nuts...4
  - ④⑤ Sus. Shafts (A) (Silver)...2
  - ⑤④ M3 Pillow Balls (Silver)...6
  - ④⑩① E Rings (E-2.5) ...2
- 

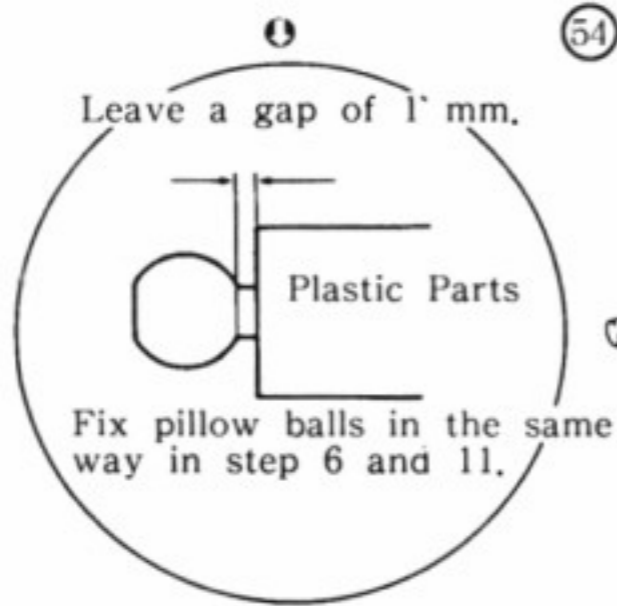

### Stage 3

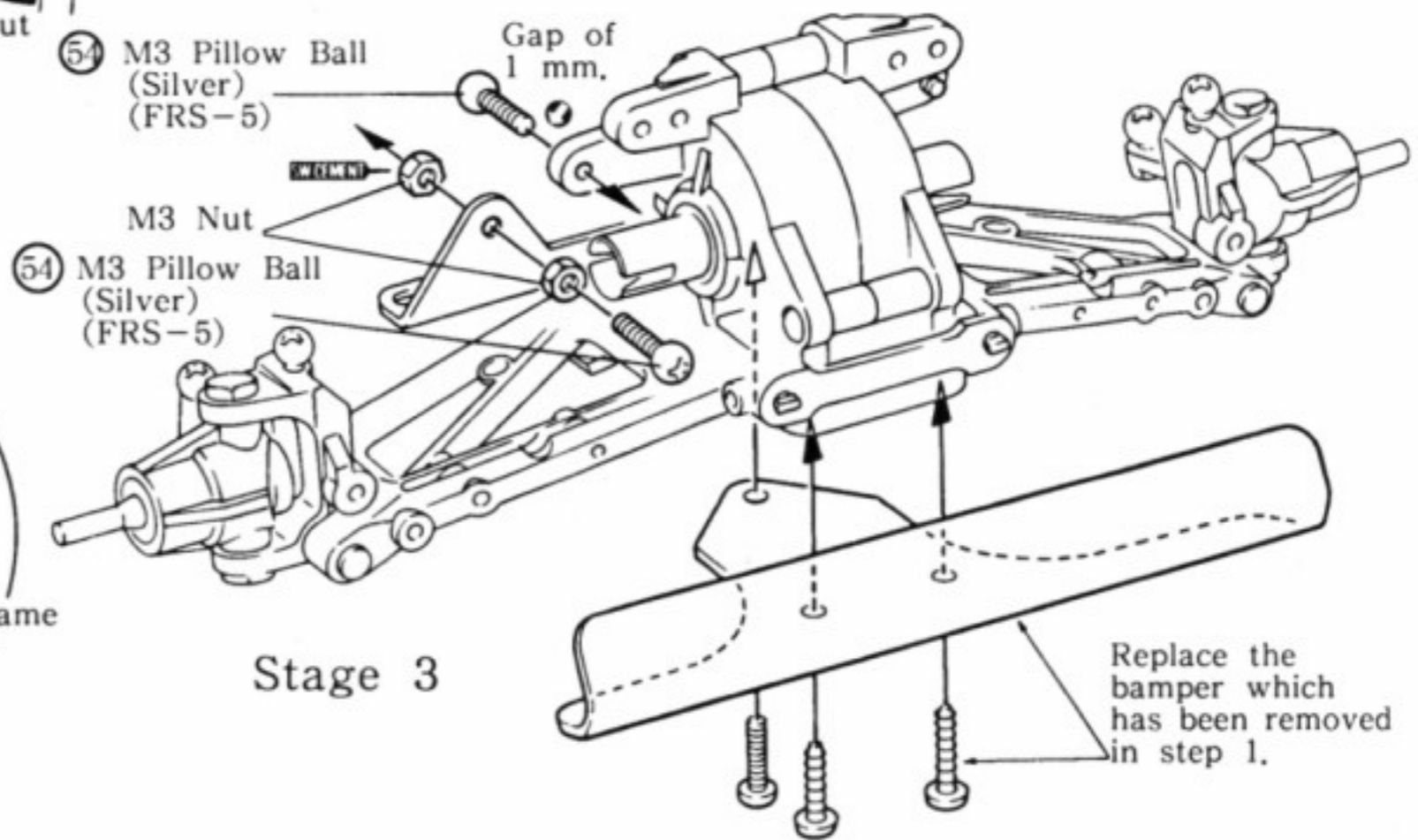

## 5 ASSEMBLY OF UPPER ROD AND TIE ROD

• Screw in the ball ends to the length as shown at right.

- ⑤⑤ Ball Ends...12
  - ⑦⑨ 5.8 φ Balls...2
- 

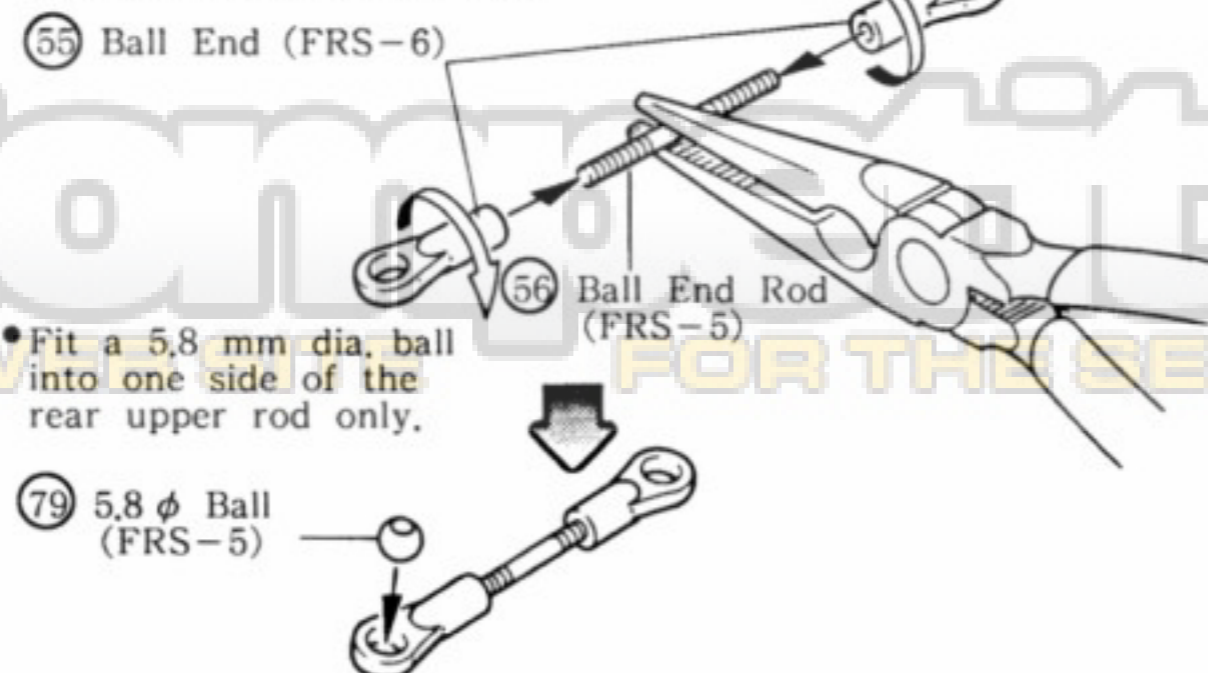

[Actual Size]

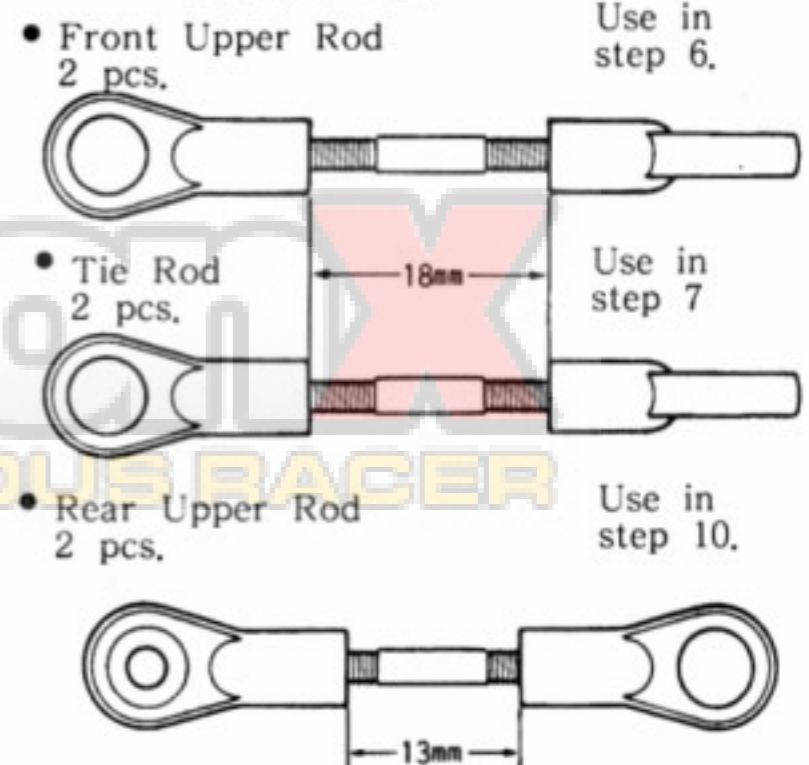

## 6 INSTALLATION OF FRONT UPPER ROD

This is the front upper rod which has been assembled in step 5.

⑤④ M3 Pillow Balls (Silver)...2

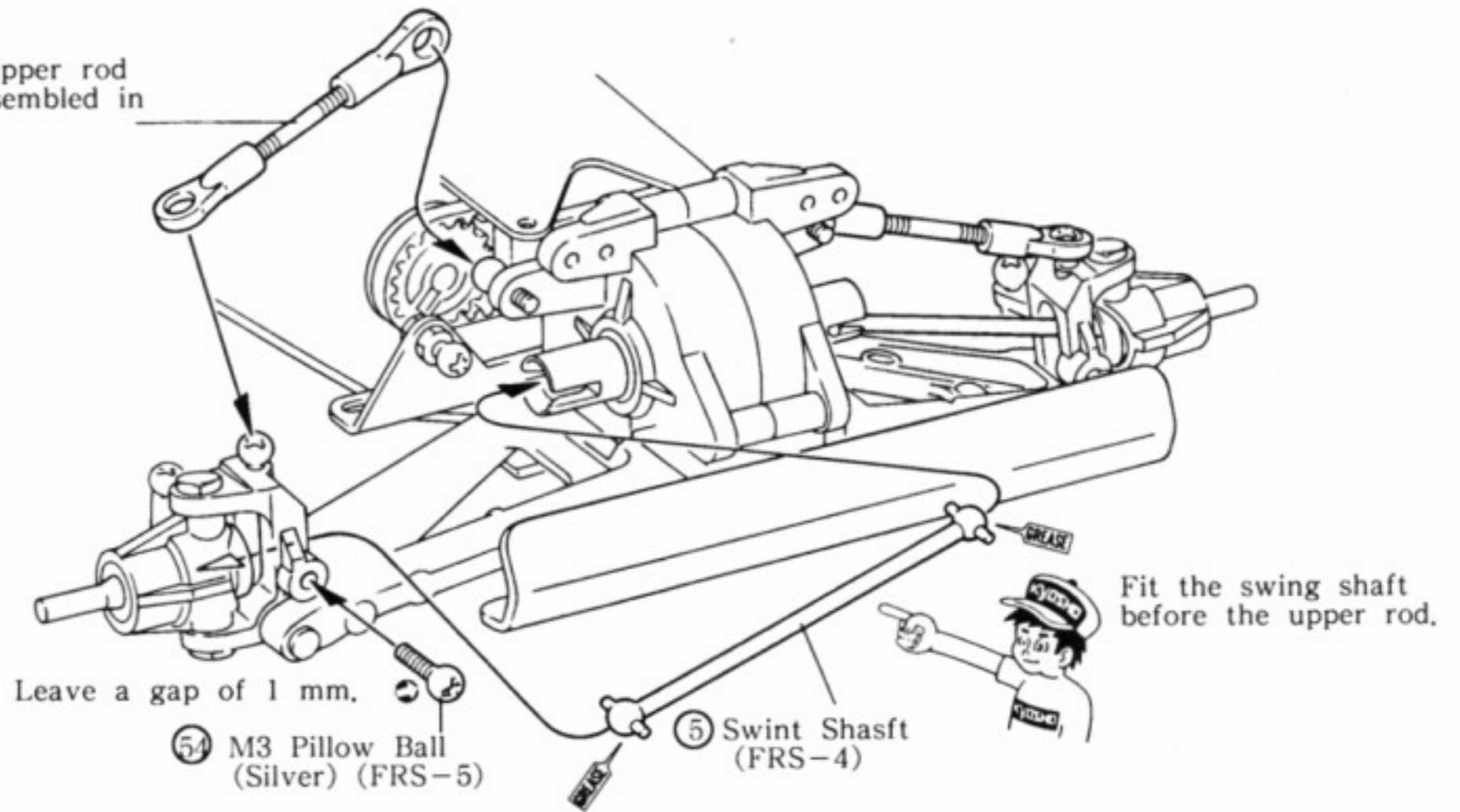

## 7 INSTALLATION OF FRONT SHOCK AND TIE ROD

This is the tie rod which has been assembled in step 5.

M3x12 Round Head Screws...2

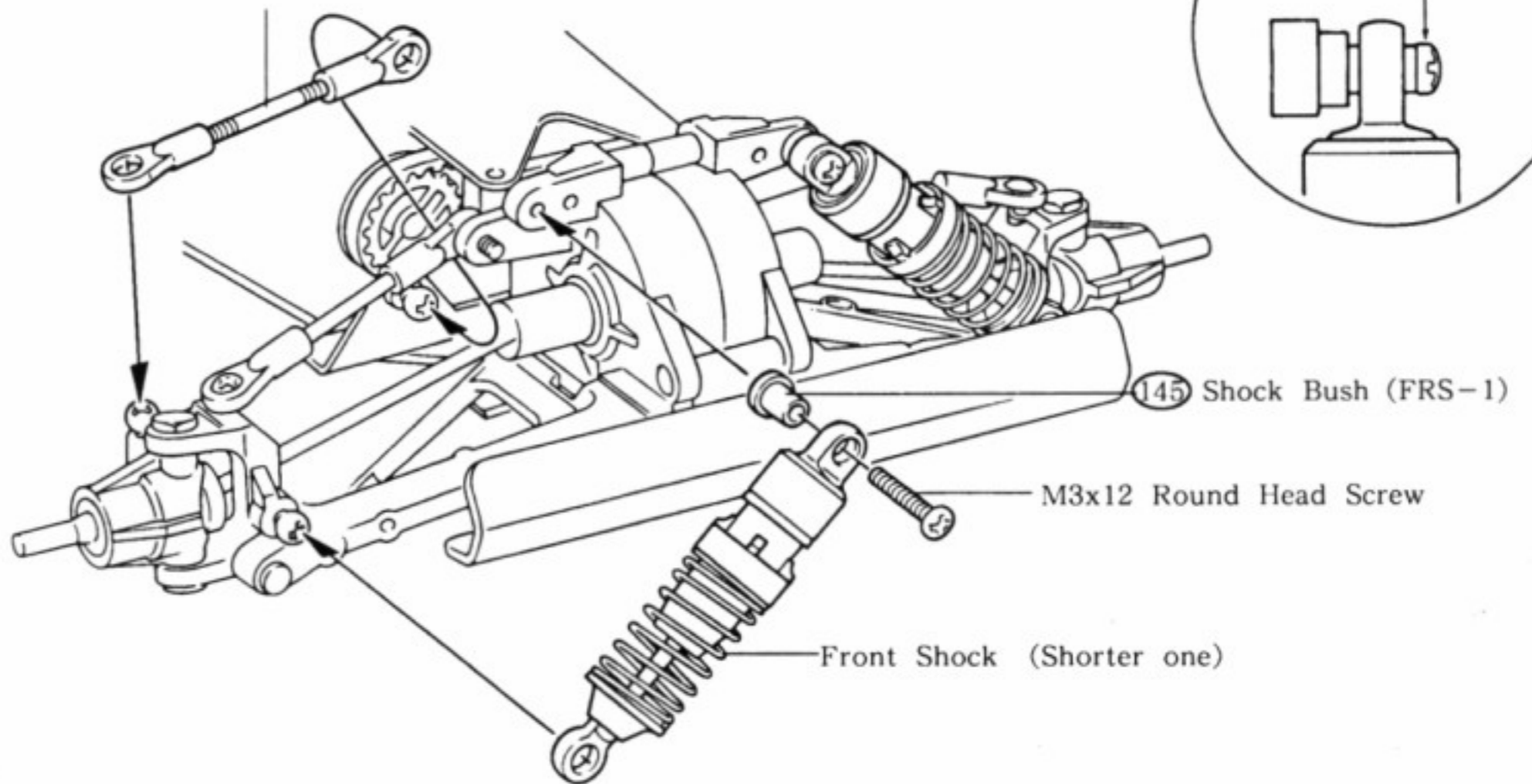

## 8 INSTALLATION OF REAR HUB

①②① 5 φ x10 Plane Bearing (FRS-4)    ③⑦ Rear Wheel Shaft (FRS-4)

Stage 2

⑦⑧ Rear Hub (R)

M4x8 Set Screws...2

①⑥ Sus. Shafts (B) (Black)...2

①①⑧ E Rings (E-2.5) ...2

①②① 5 φ x10 Plane Bearings...4

Stage 1

[Right]

⑦⑧ Rear Hub (R) (FRS-6)

④⑧ Sus. Shaft (B) (Black) (FRS-5)

⑦⑦ Rear Hub (L) (FRS-6)

①①⑧ E Ring (E-2.5) (FRS-3)

This is the screw to adjust the car clearance. By screwing in, you will have less clearance, and the other way more body clearance.

M4x8 Set Screw

[Right]

④④ Rear Sus. Arm (FRS-6)

Be careful about the installing direction.

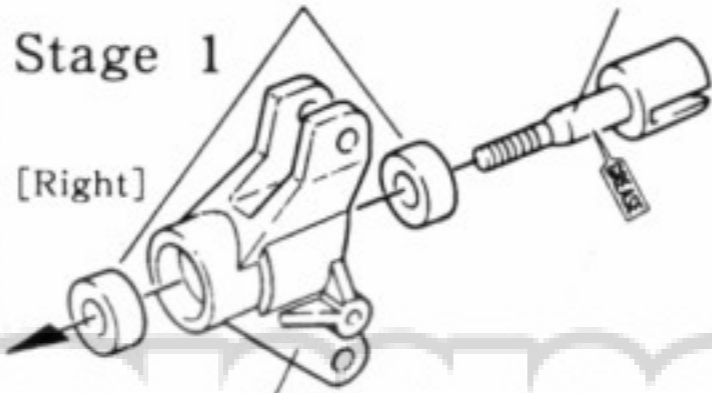
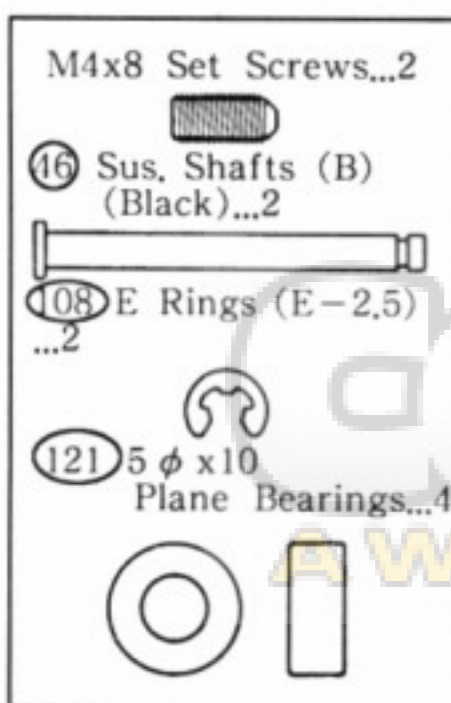

[Left]

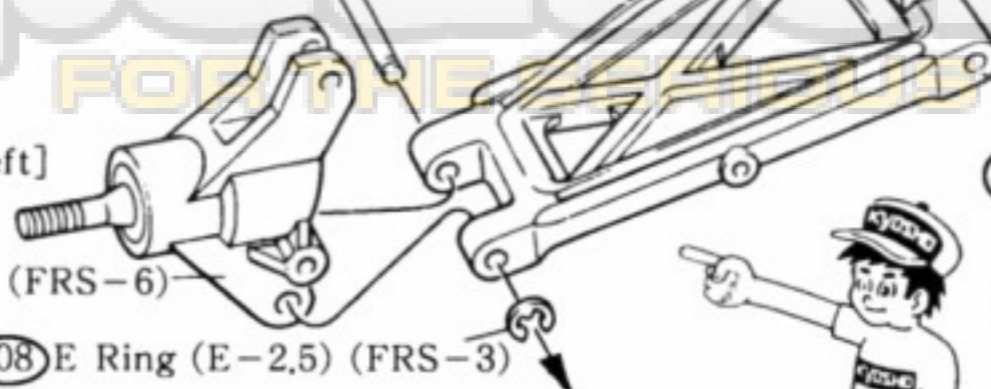



## 9 INSTALLATION OF REAR AND EACH PARTS

This illustration shows the left side installation. Assemble the right counterpart in the same way.

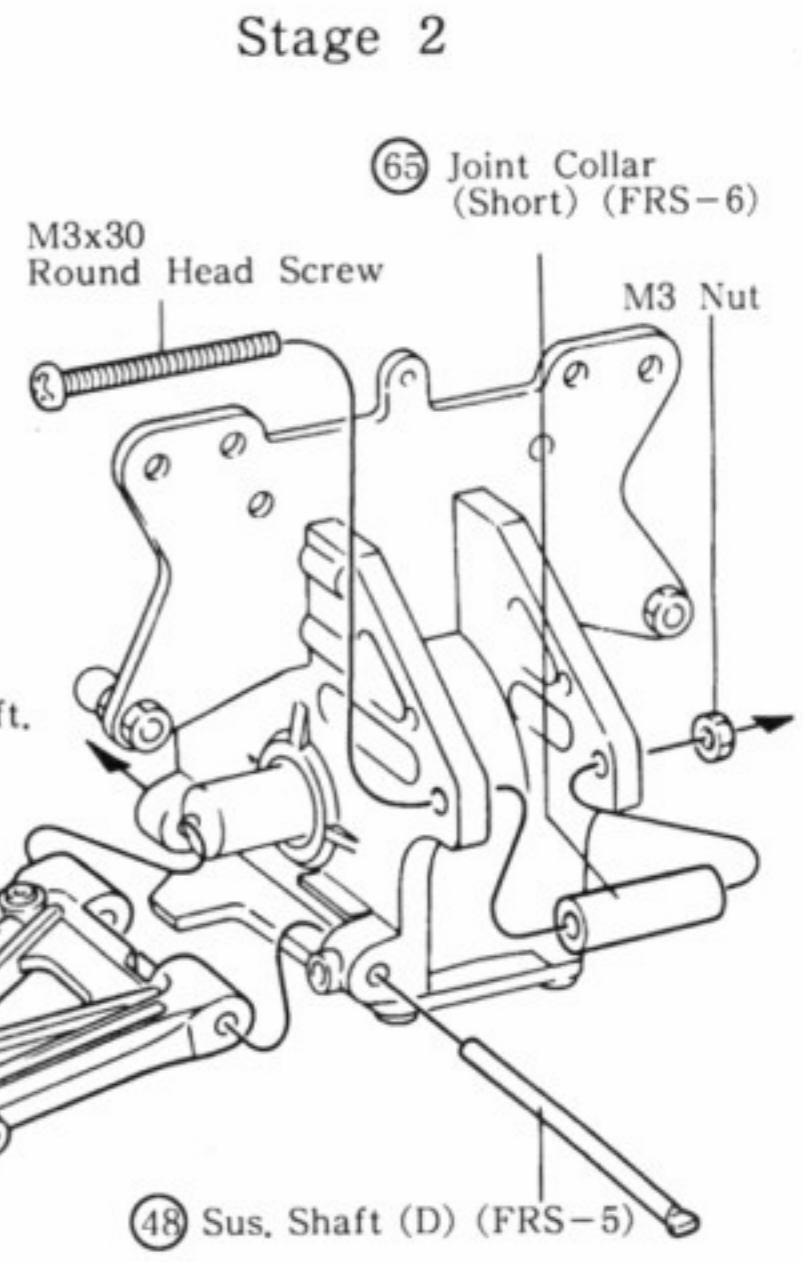
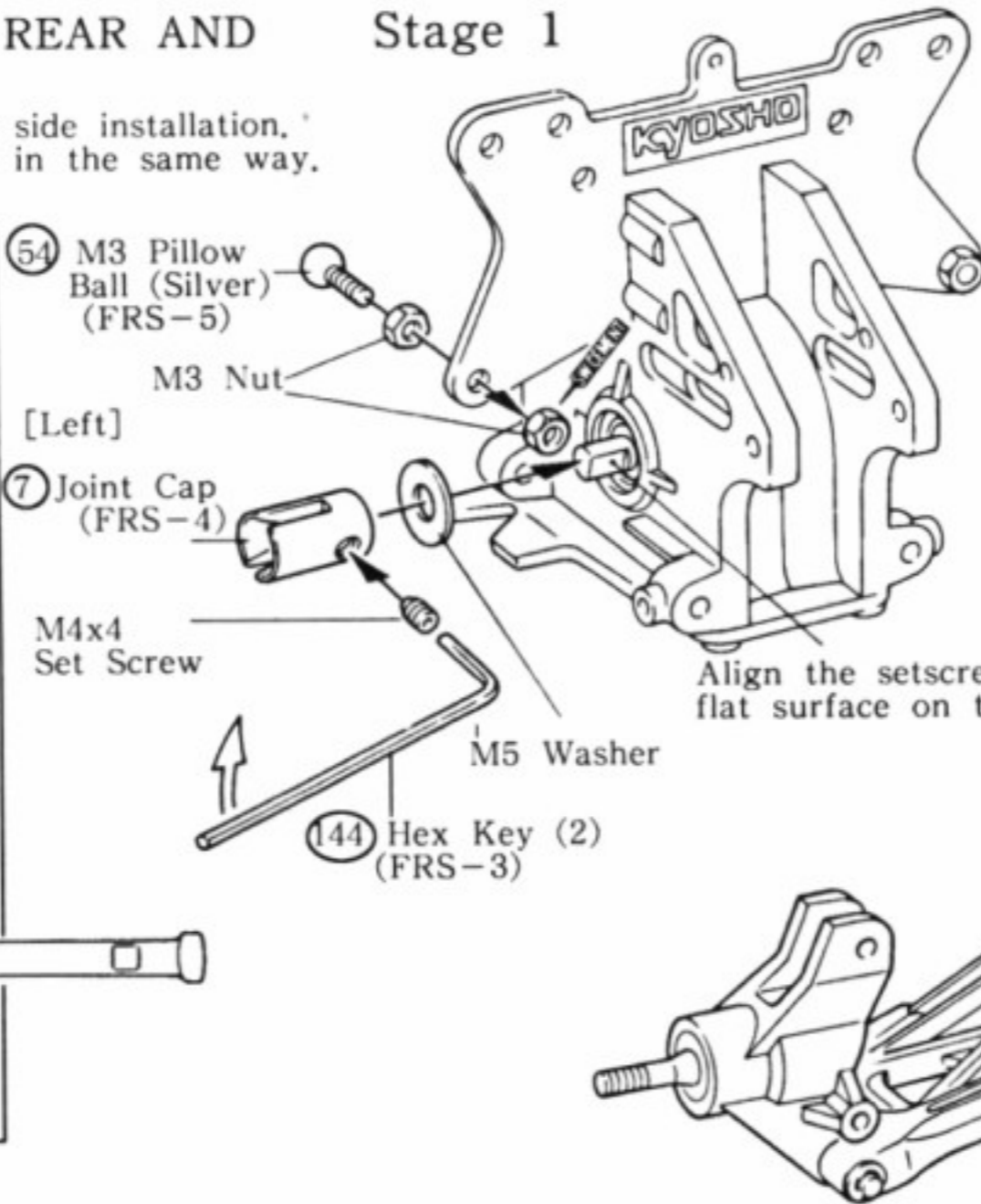
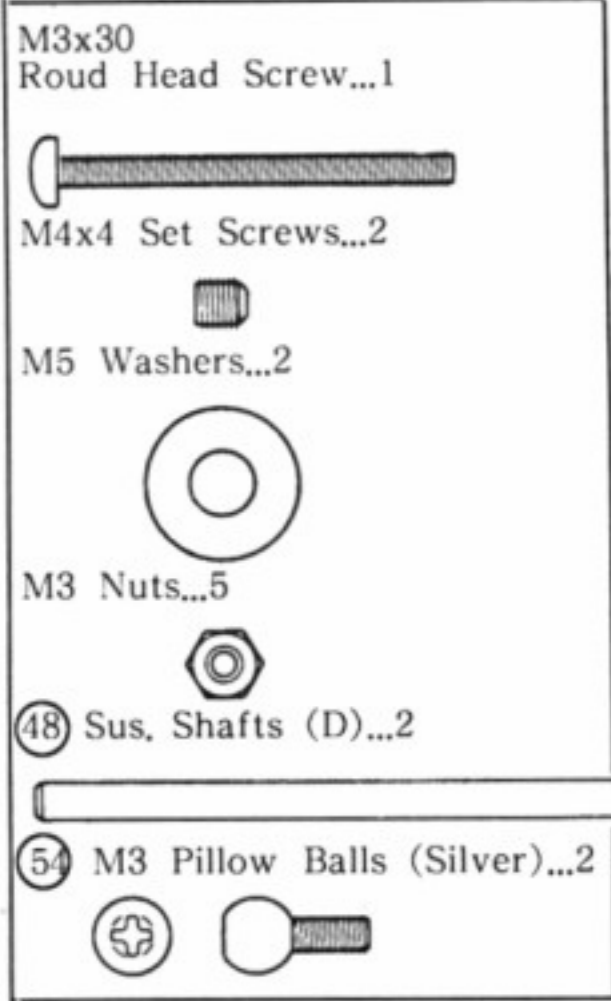

## 10 INSTALLATION OF REAR UPPER ROD

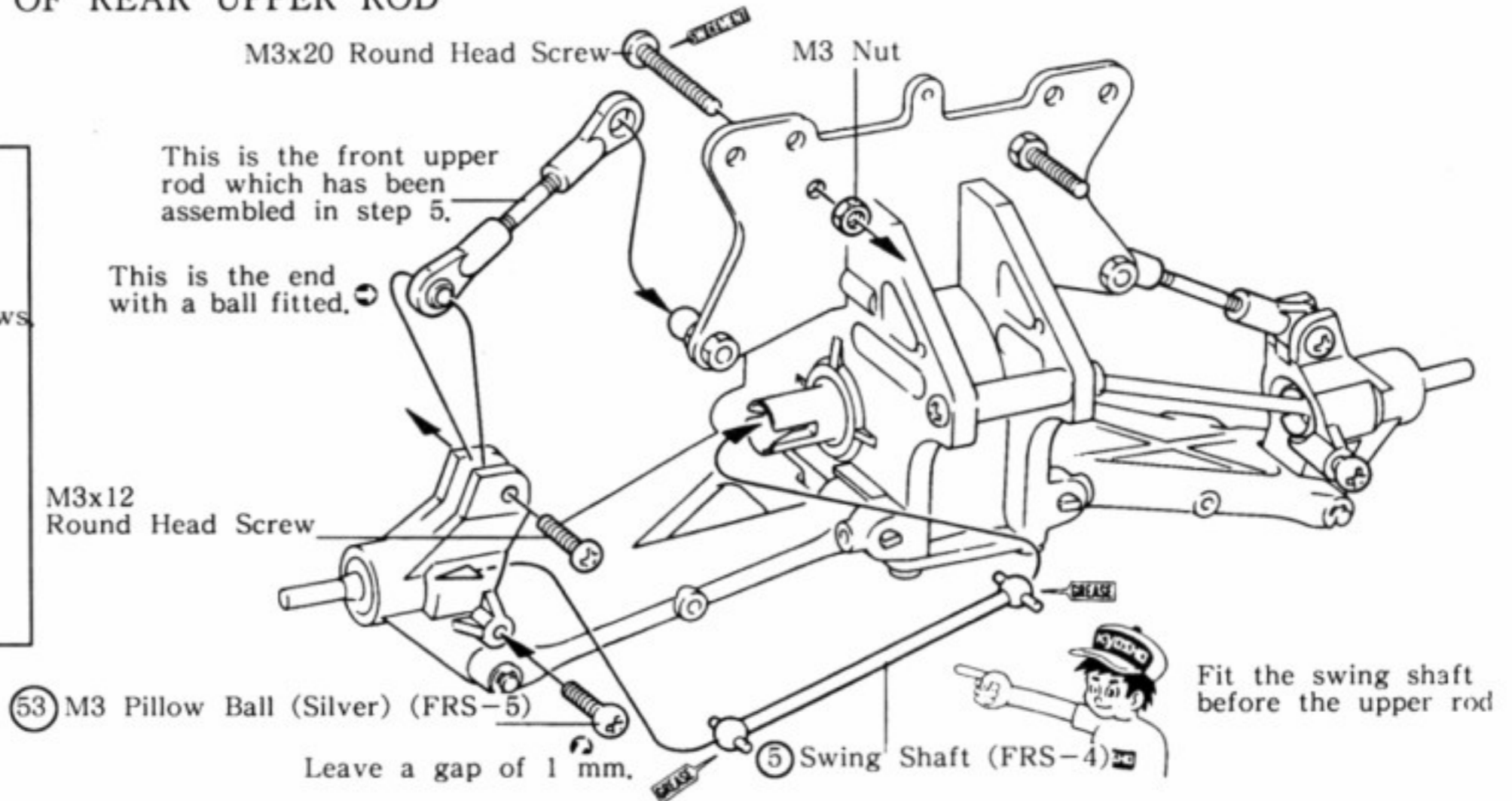
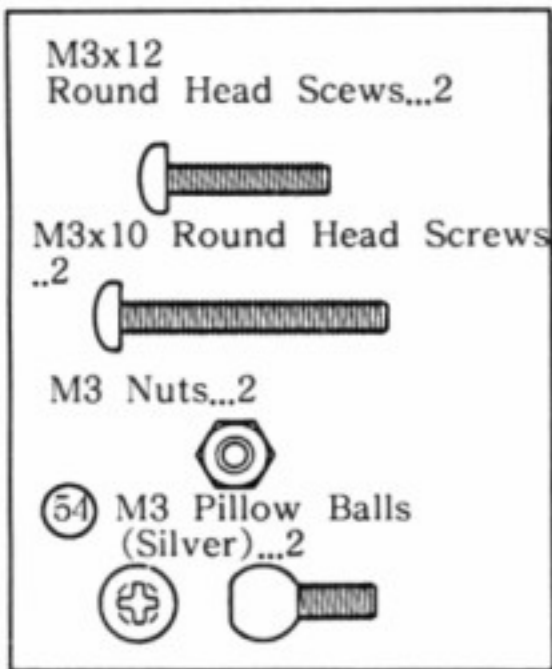

Fit the swing shaft before the upper rod

## 11 INSTALLATION OF REAR SHOCK

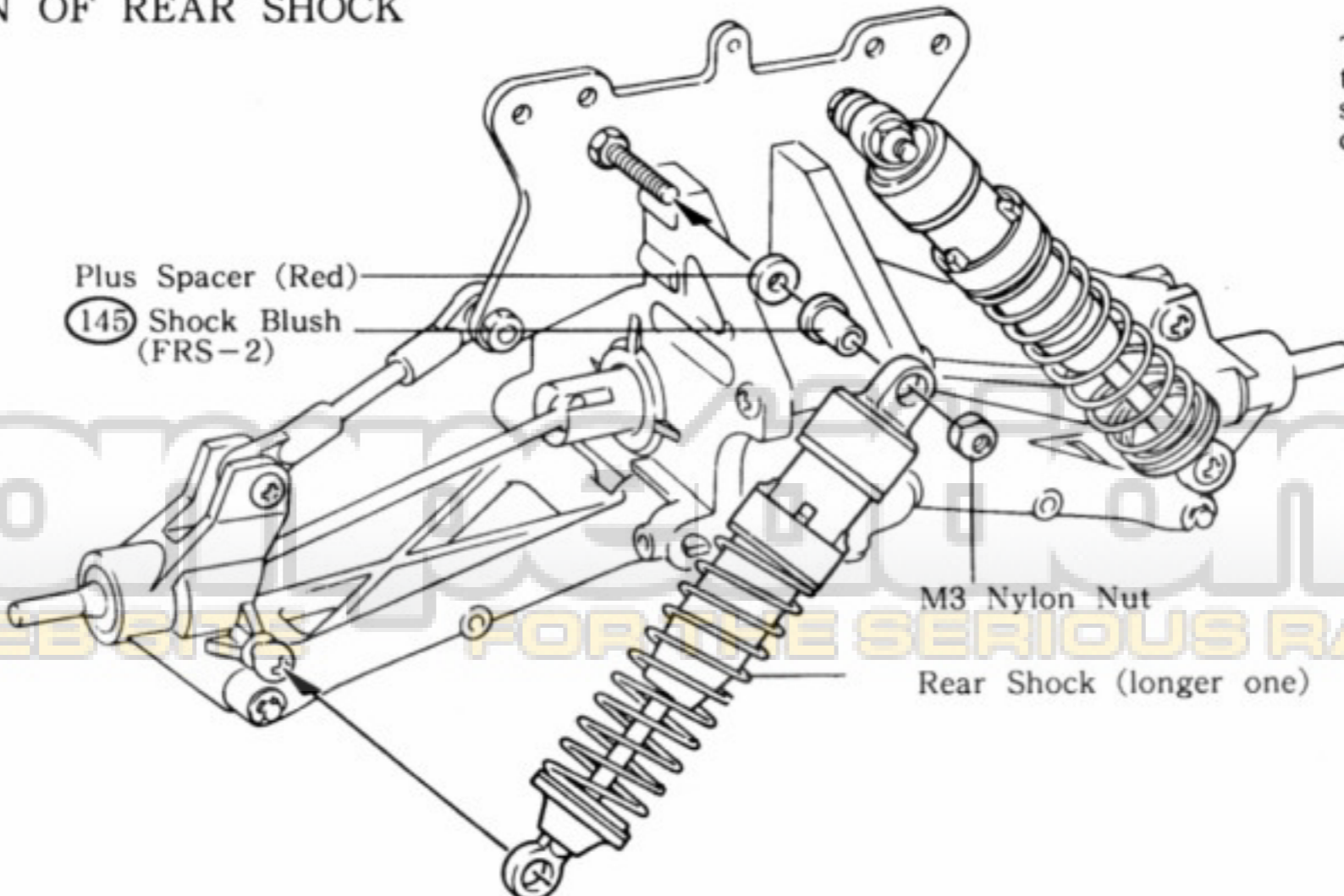
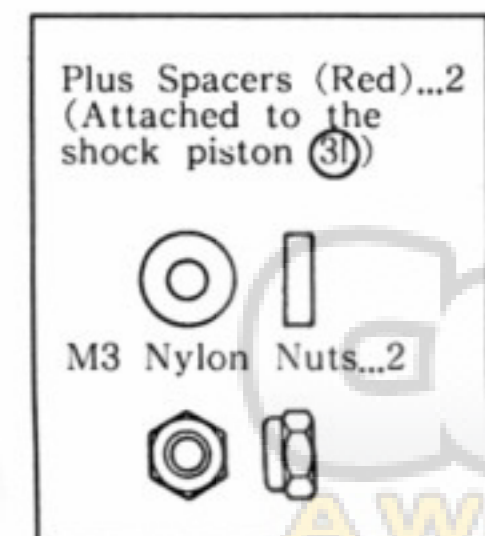

Tighten the nylon nut to the degree so that the shock bushing will be crushed.

## 12 HOW TO CHECK RADIO SYSTEM

Let's test the system by following number one by one as a step.

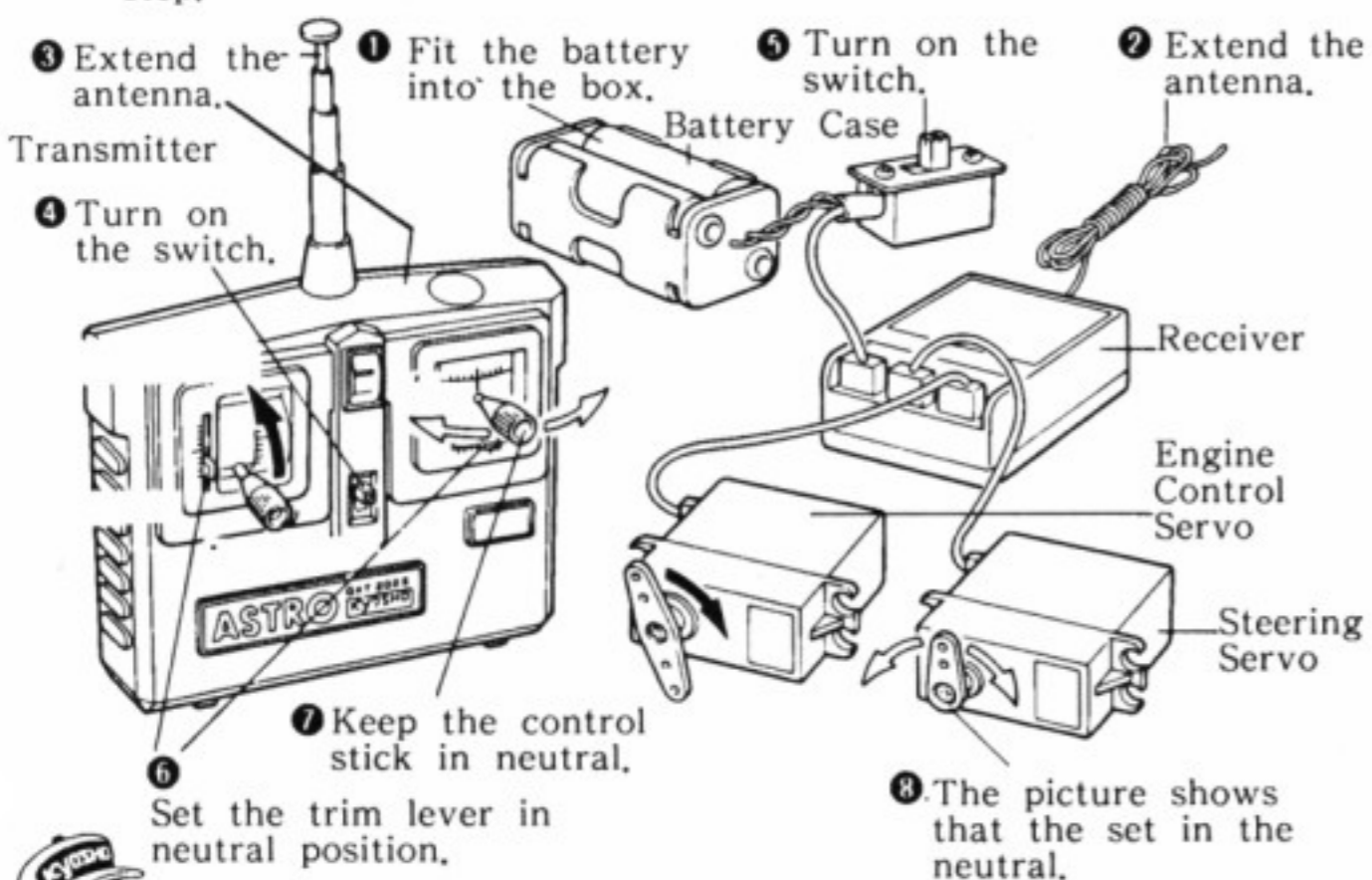

When switch on the radio...  
Get the switches in order from transmitter to receiver.  
When switch off the radio...  
In order from receiver to transmitter.

A two channel radio is composed of things like a transmitter, receiver, servos, and battery.

- \* Transmitter ..... It is control box which manipulates by stick movements. Signal waves are transmitted through on antenna.
- \* Receiver ..... Receives the signals from the transmitter and send them to the servos.
- \* Servo ..... They move the control mechanism of a model car in accordance with the signals from the receiver.
- \* Antenna ..... An antenna on the transmitter sends signals, and one on the receiver accepts them. They should be fully extended.
- \* Trim ..... They will adjust the neutral position of servos, thus regulate the steering and advancing controls finely.
- \* Battery Meter ..... You can tell the amount of electricity in a battery and how the signals are emitted.
- \* Servo ..... They are intermediate devices on the servos to activate the controls. There are several types in shape. They should be selected depending upon the usage.

## 13 INSTALLATION OF SERVO

Engine Control Servo (Mount it in the same way as done with the steering servo.)

M3x10  
TP Bind Screws...2

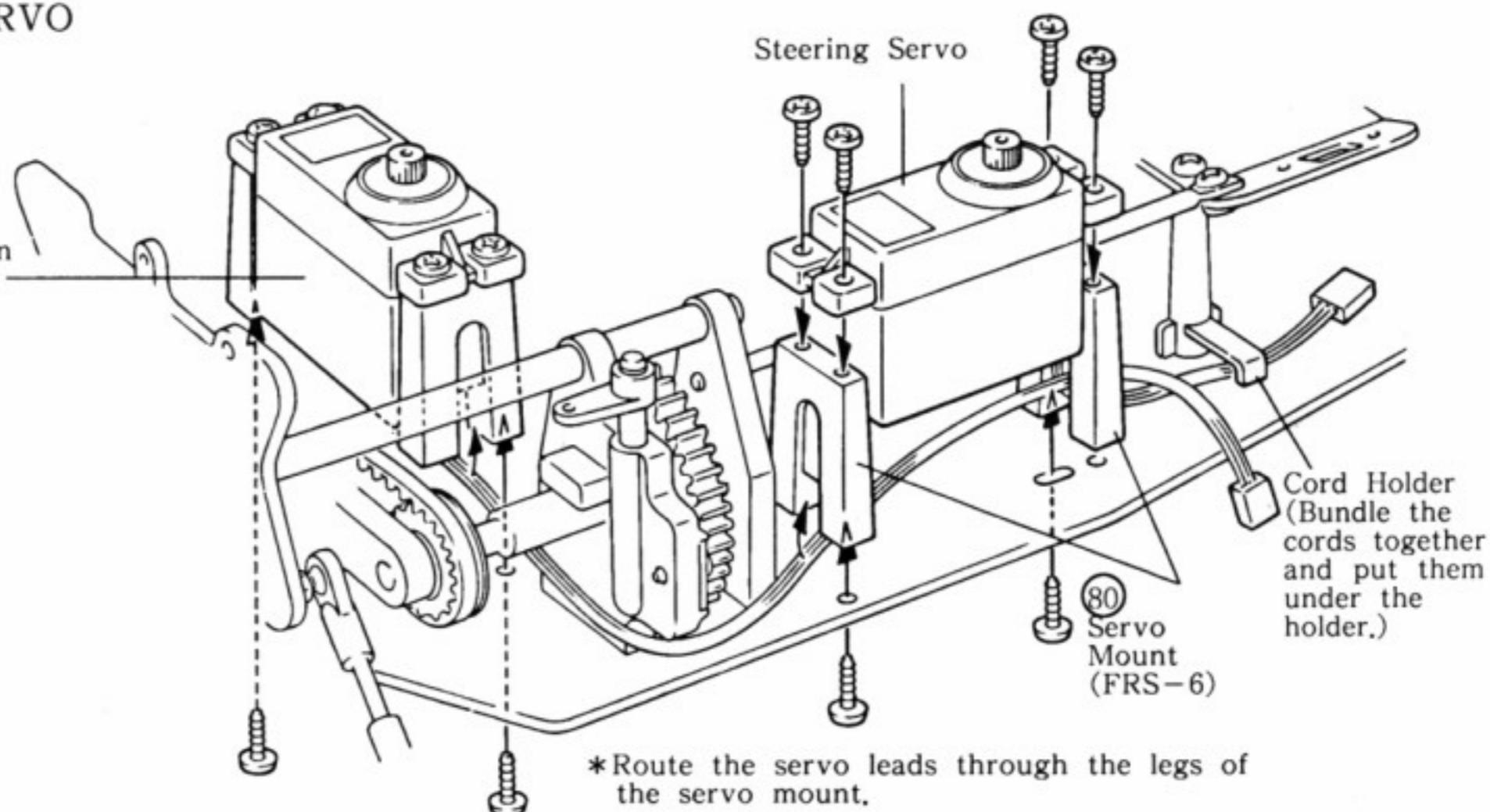

## 14 INSTALLATION OF RADIO SYSTEM

The screws which are provided with your radio.

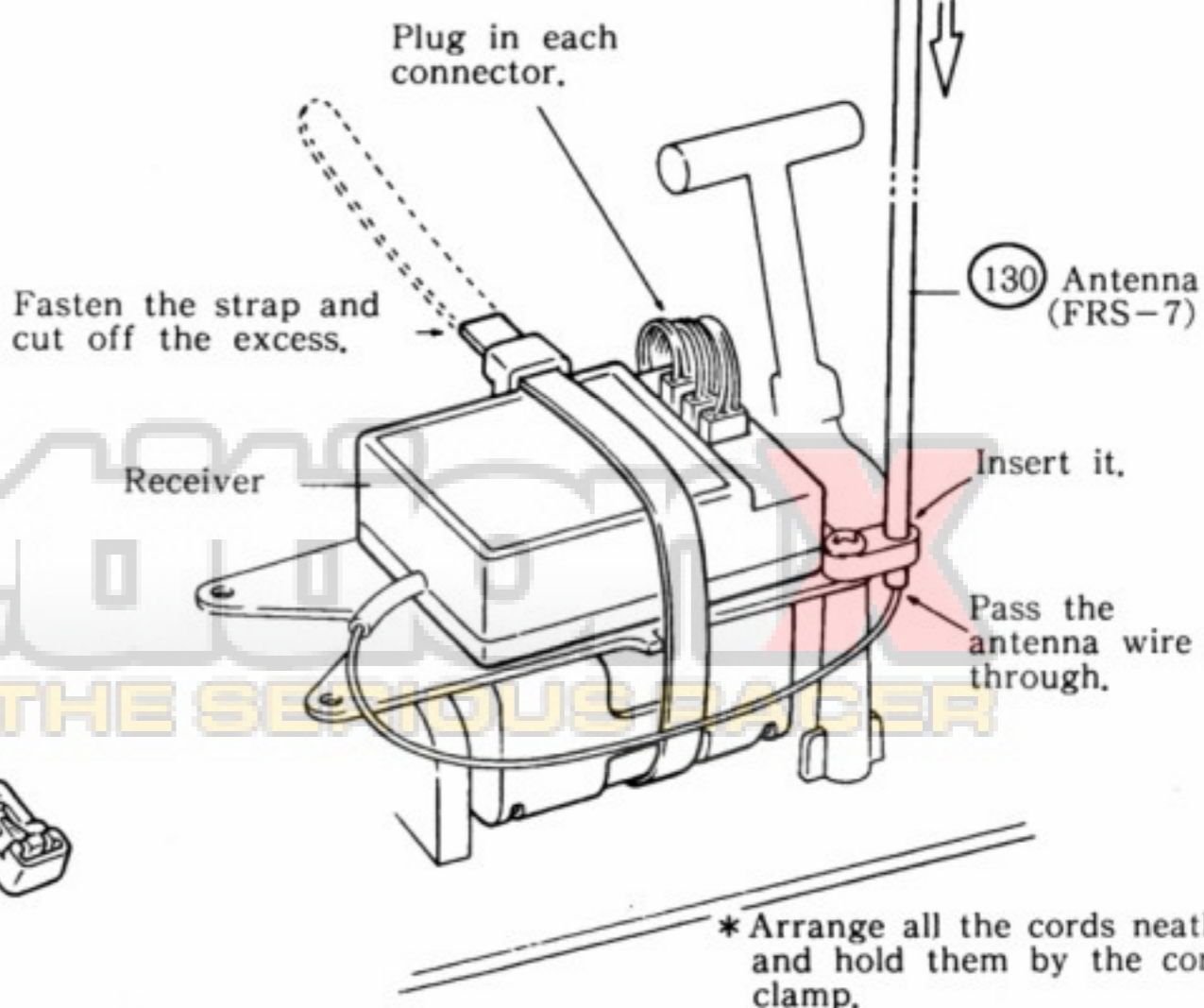
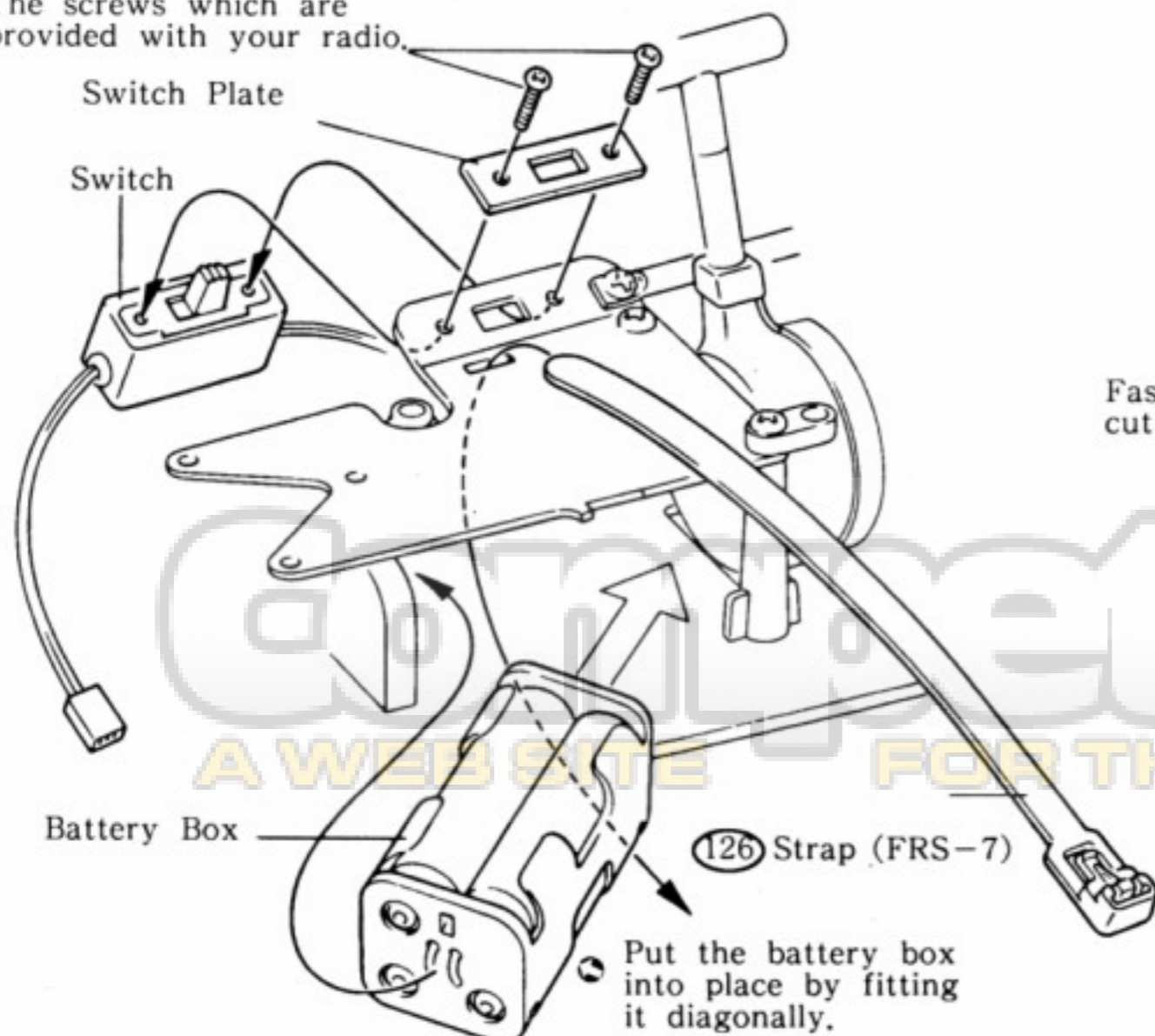

# 15 STEERING LINKAGE

- M3x3 Set Screw...1
- M3 Nylon Nut...1
- Plastic Spacer (Red)...1 (Attached to the shock piston (31))
- 118 3 φ Linkage Guide...1

## Stage 1

Enlarge the hole to the thickness of the rod.  
 [Trimming off of servo horn] Cut off the shaded portions, they will not be used.  
 Connect the control rod to the hole which is 16 mm away from the center.

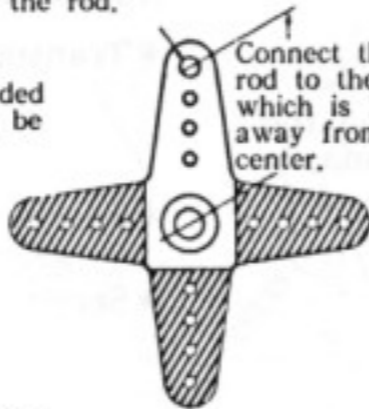

## Stage 2

Bend the control rod at the point marked with an arrow as shown below and at right.  
 The screws which are provided with your radio.

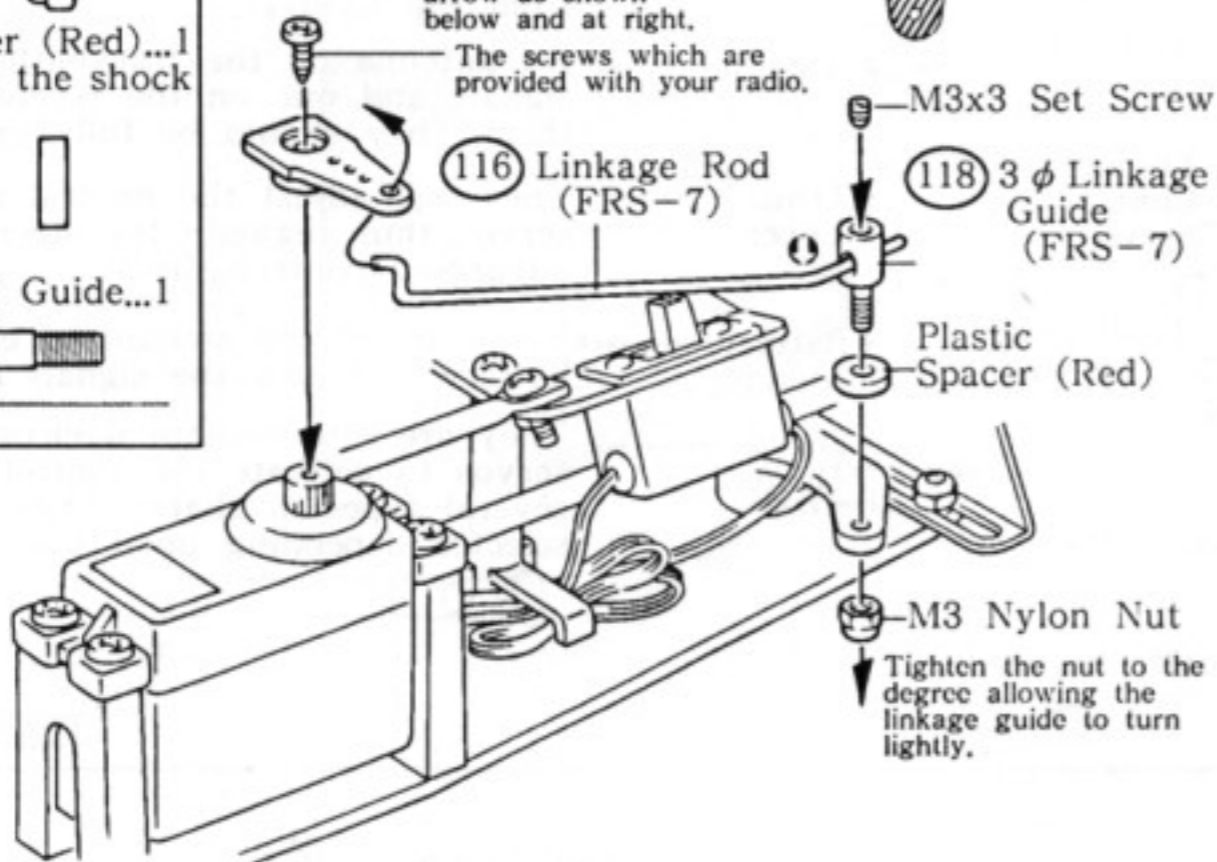

### [Position of steering stick]

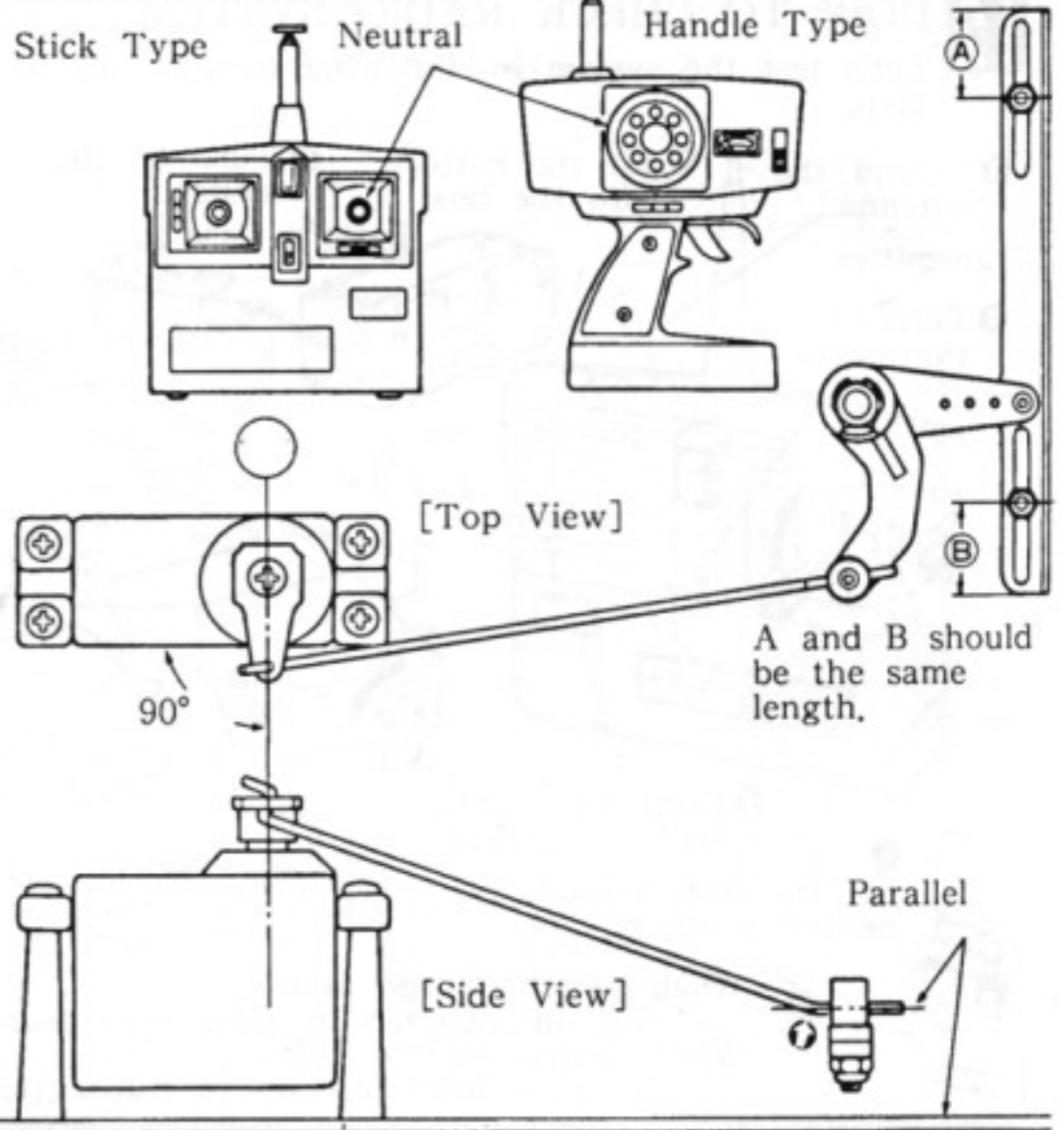

# 16 ENGINE CONTROL LINKAGE

- M3x3 Set Screws...2
- 117 2 φ Linkage Guide...1
- 119 Rod Stoppers...2

## Stage 1

[Trimming off of servo horn] Cut off the shaded portions, they will not be used.

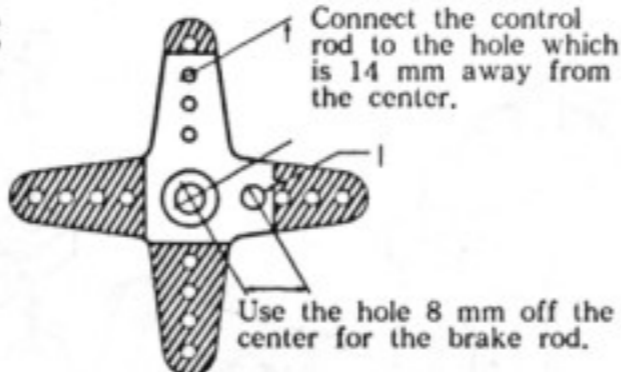

## Stage 2

### [Position of engine control]

- Stick Type
- Handle Type

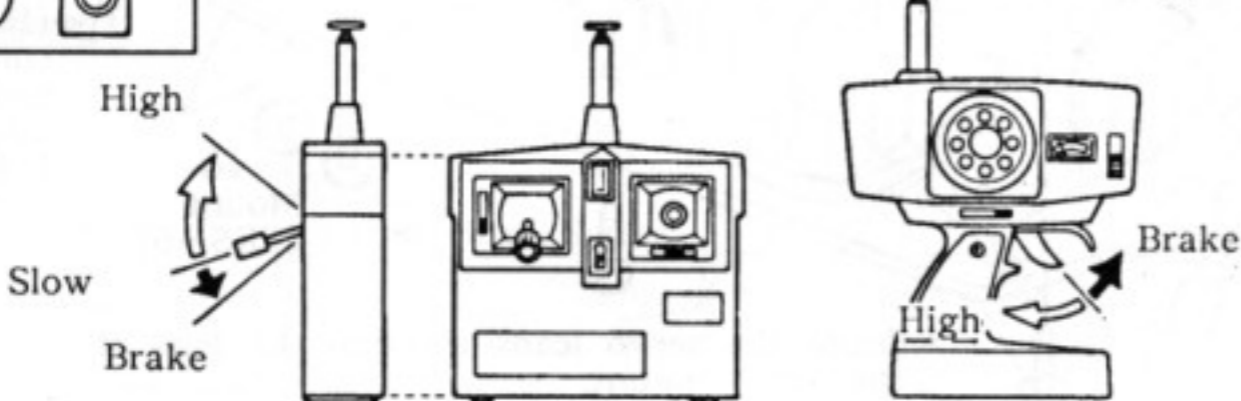

## Stage 3

116 Linkage Rod (For Brake) (FRS-7)  
 The screws which are provided with your radio.

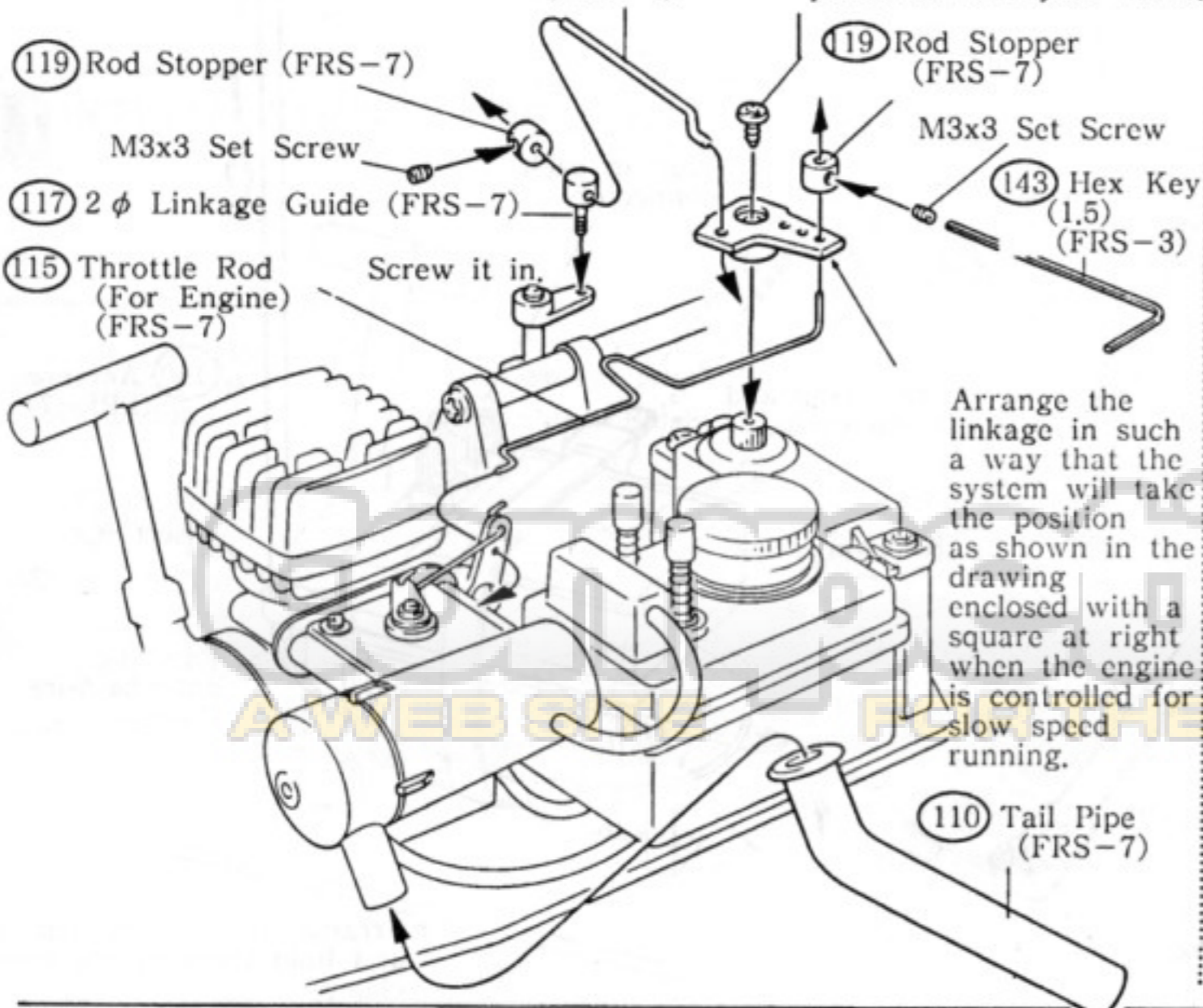

### [Correlative movement of servo horn and control rod]

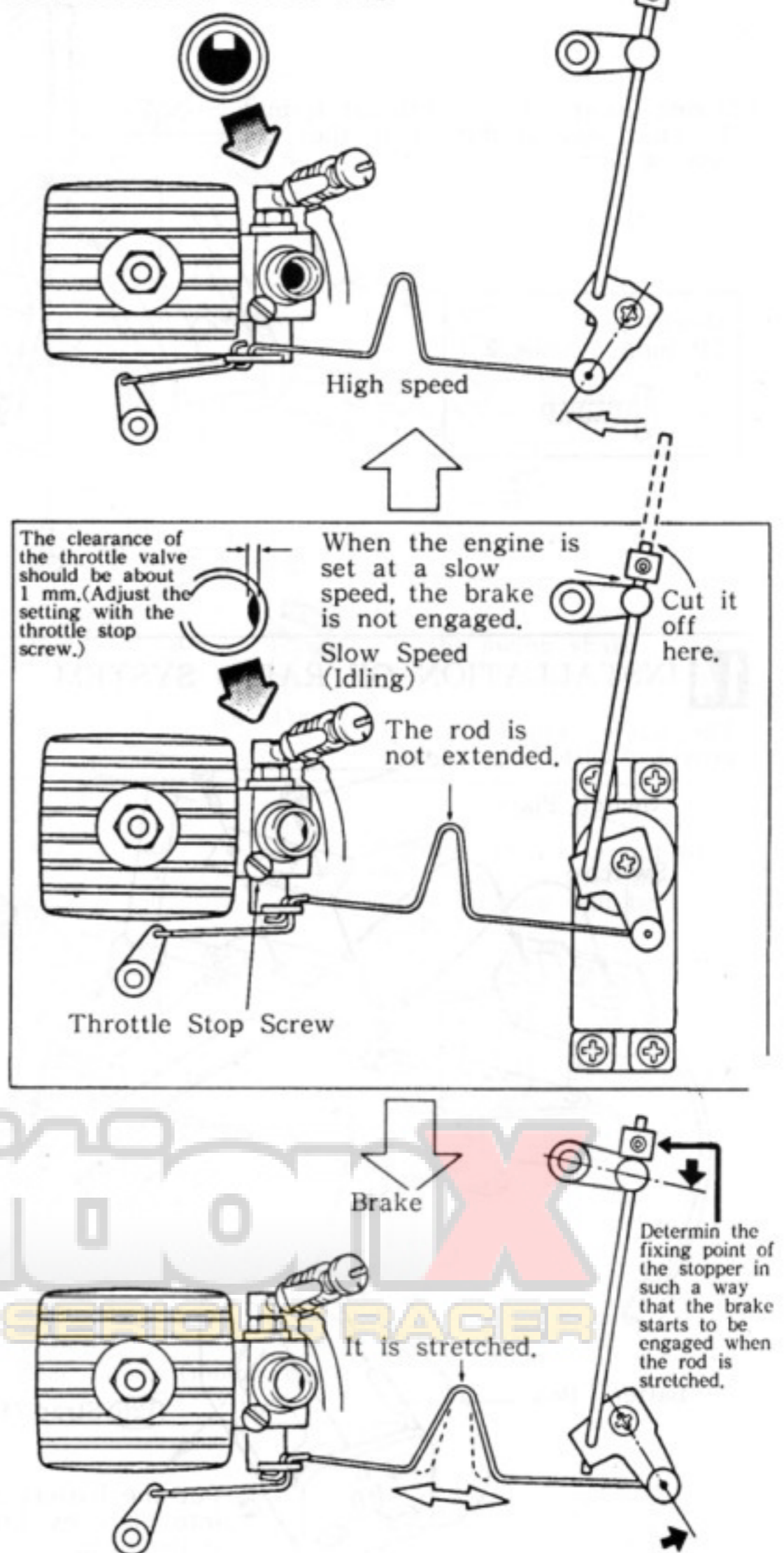

# 17 INSTALLATION OF TIRE

M4 Nylon Nuts...4



## Stage 1

[Fixing of wheel and tire]  
This illustration shows the right side wheel. In the case of the left side, everything is the same but the direction of the tread pattern is opposite.

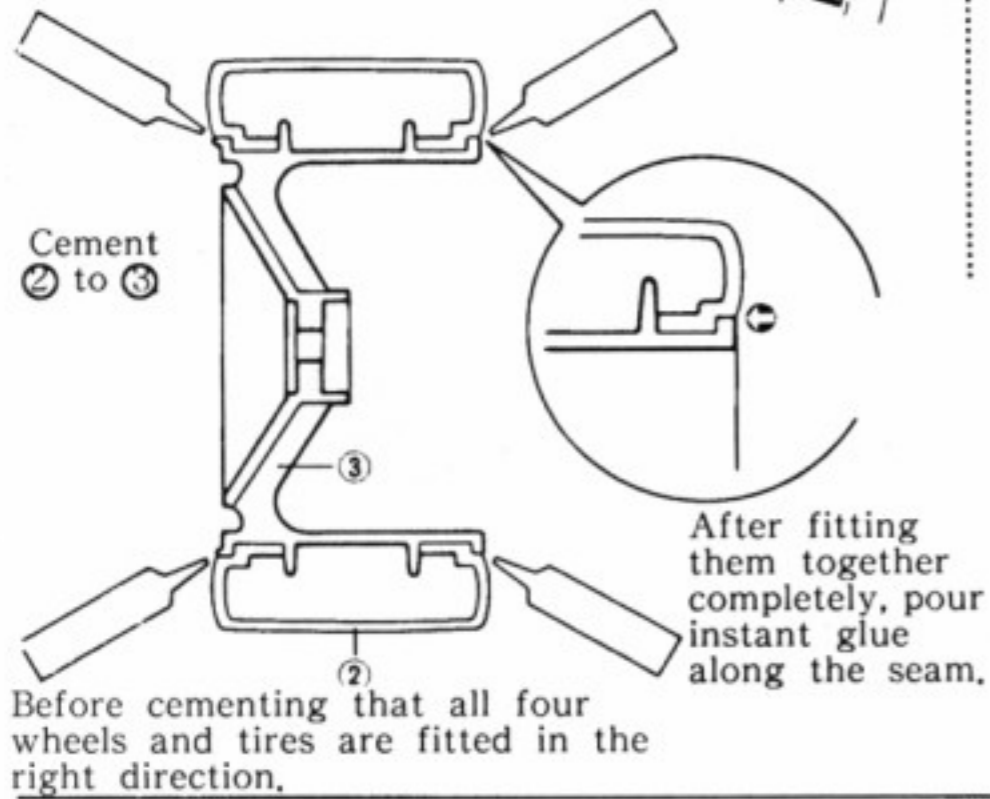
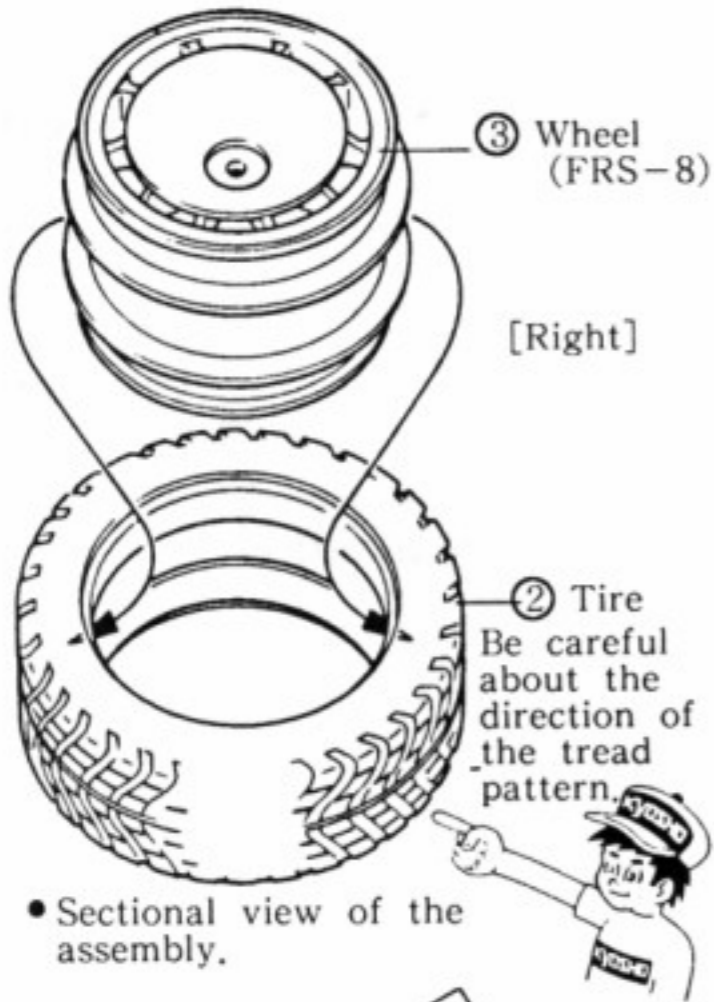

[Right direction of tire patterns]

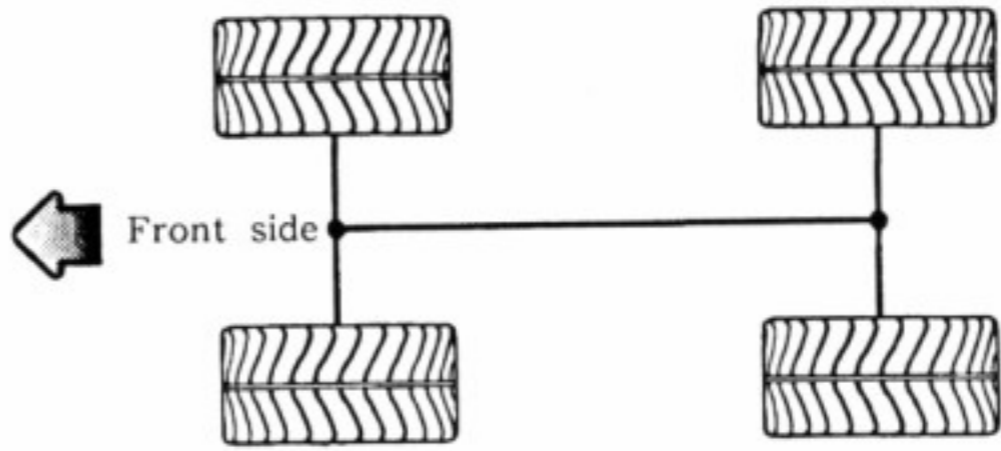

## Stage 2

[Installation of tire]

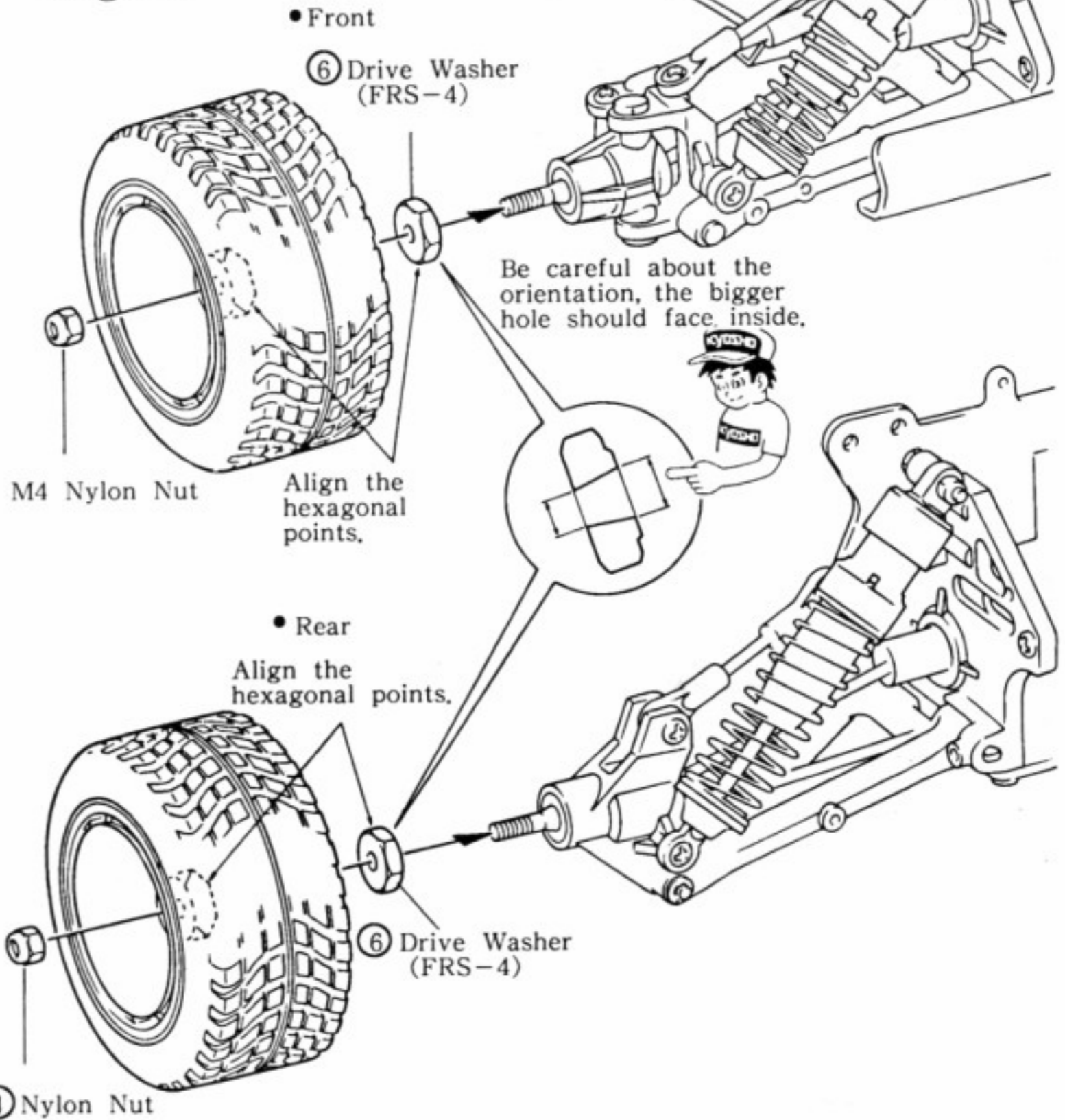

# 18 CUTTING OF BODY

Cut out the roof portion. Body Installing Holes

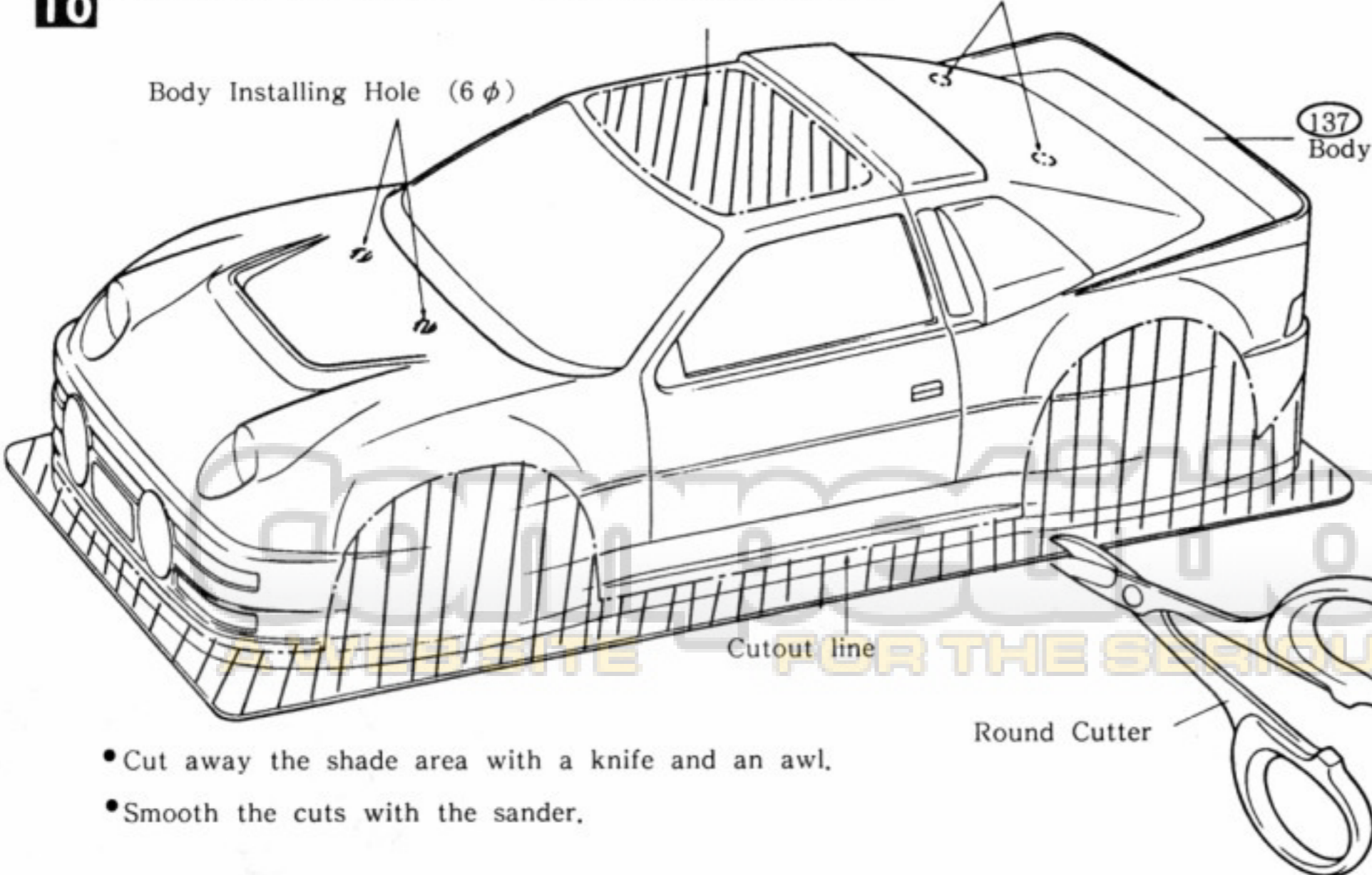

**KYOSHO**

• These special Lexan Scissors make trimming bodies a breeze and the sander comes in handy for finishing the rough edges.

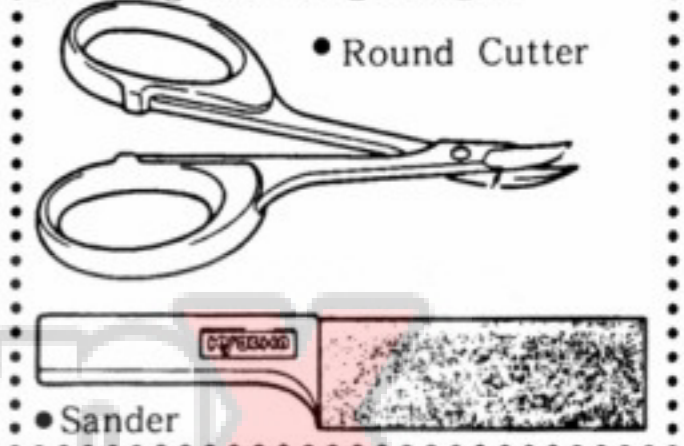

- Cut away the shade area with a knife and an awl.
- Smooth the cuts with the sander.

## 19 PAINTING

First, wash the body to remove any oil or dirt. Rinse thoroughly. Paint the inside of body. You can obtain a color scheme by masking a portion with tape then removing the tape and painting. Apply the lightest color last.

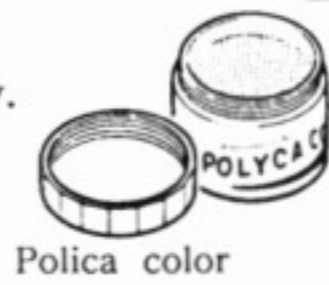

Polica color

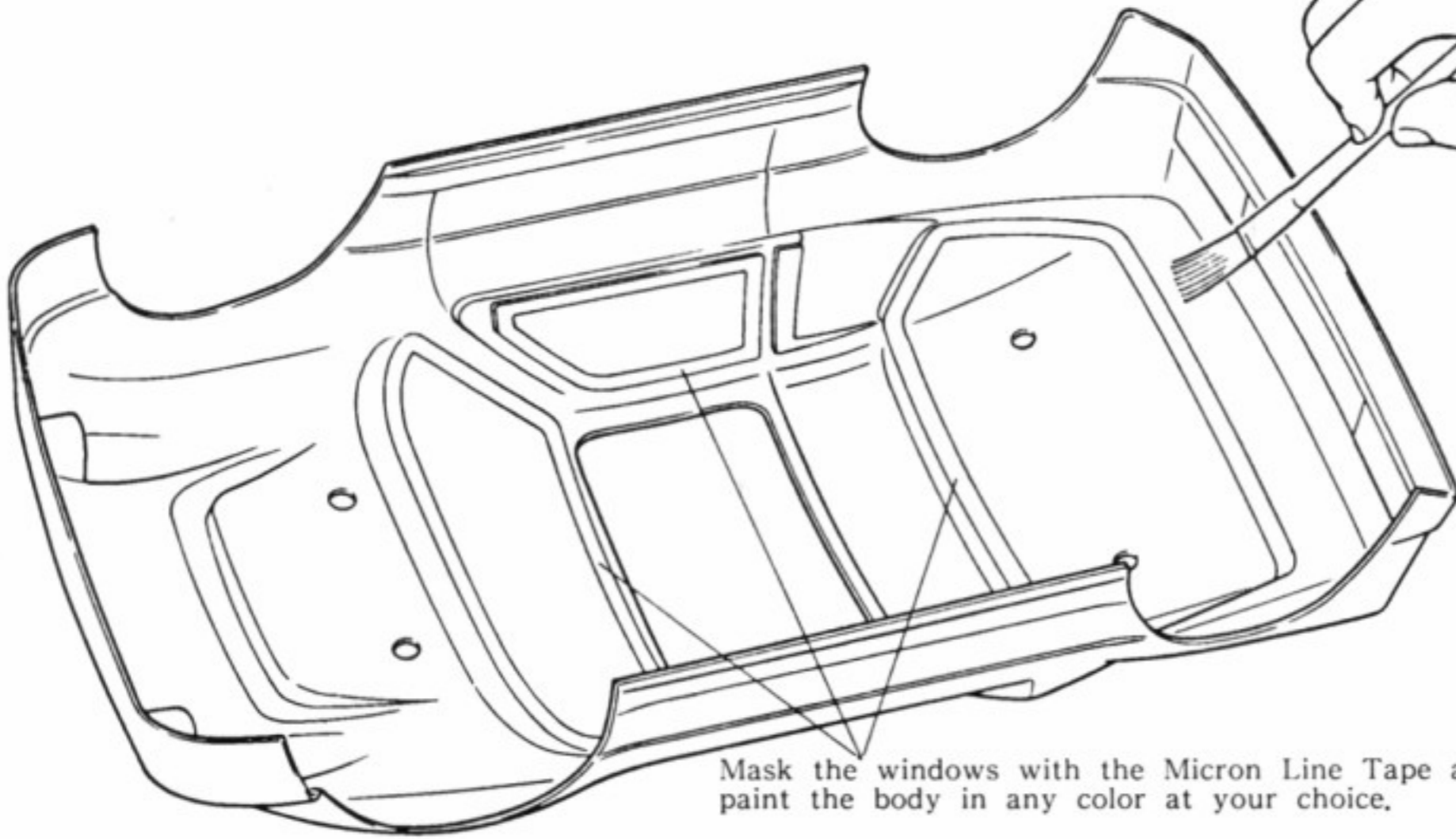

**KYOSHO**

- Micron Line Tape No.1841...1mm
- No.1842...1.5 mm
- No.1843...2.5mm
- Color
- White,Red,
- Yellow,Green
- Blue & Black



**KYOSHO**

- Polica Color No.2230
- White,Red,Yellow,
- Green, Blue,Sky Blue,
- Orange,Black,Violet,
- F,Pink,Yellow Green &
- Orange



Mask the windows with the Micron Line Tape and paint the body in any color at your choice.

## 20 PAINTING OF DECAL

- Cut off the decals along the cutout line with scissors.
- Do not apply it abruptly. Convince yourself of the position by trying the decals with the backing paper on.
- Be careful not to have air bubbles left. Try to center to the periphery. (particular be cautious with a large decal.)



Bottom

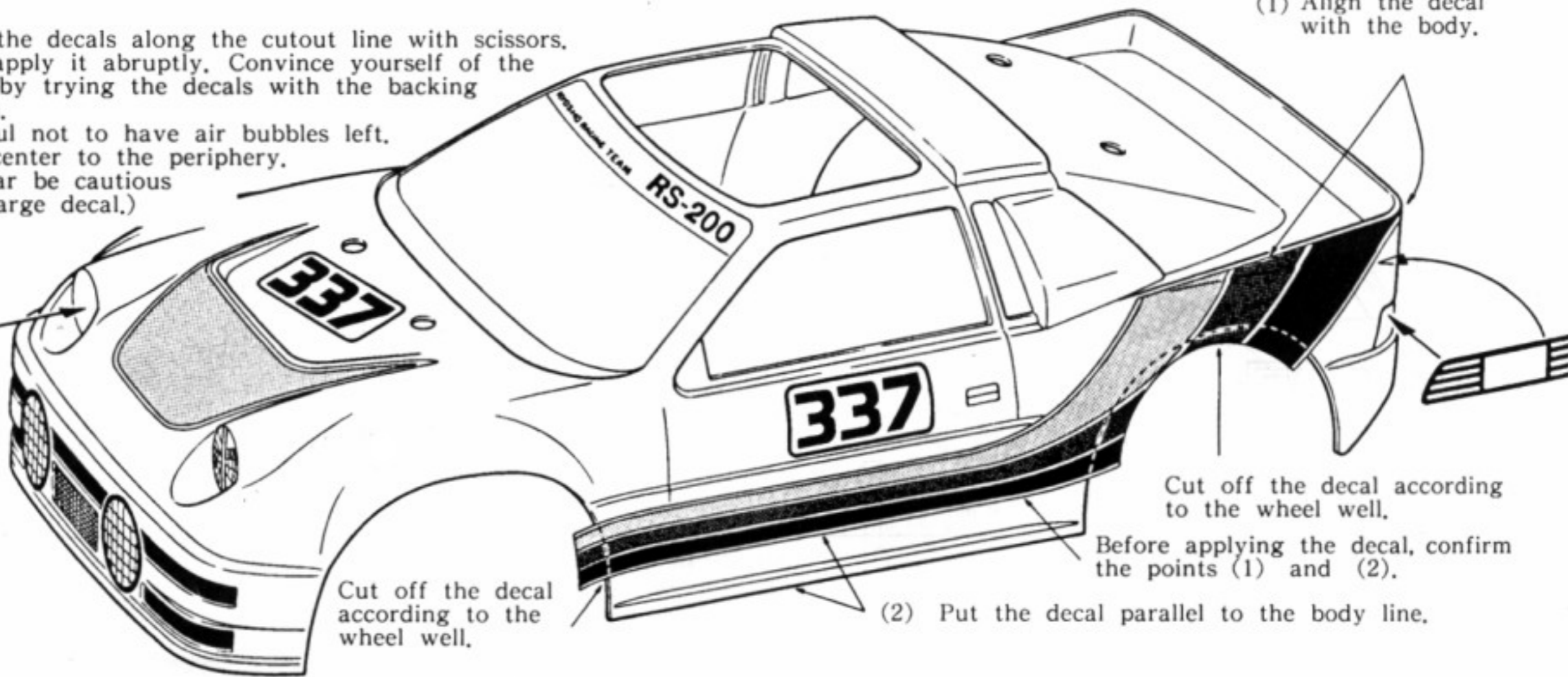

(1) Align the decal with the body.

Cut off the decal according to the wheel well.

Before applying the decal, confirm the points (1) and (2).

(2) Put the decal parallel to the body line.

Cut off the decal according to the wheel well.

## 21 INSTALLATION OF BODY MOUNT

M3x10 TP Bind Screws...6

M3x28 TP Round Head Screws...2

(135) Hook Pins...4

(135) Hook Pin (FRS-3)

(31) Body Mount (A) (FRS-6)

(32) Body Mount (B) (FRS-6)

M3x10 TP Bind Screw

[Front]

M3x18 TP Round Head Screw

(135) Hook Pin (FRS-3)

[Rear]

(131) Body Mount (A) (FRS-6)

(33) Body Mount (C) (FRS-6)

M3x10 TP Bind Screw

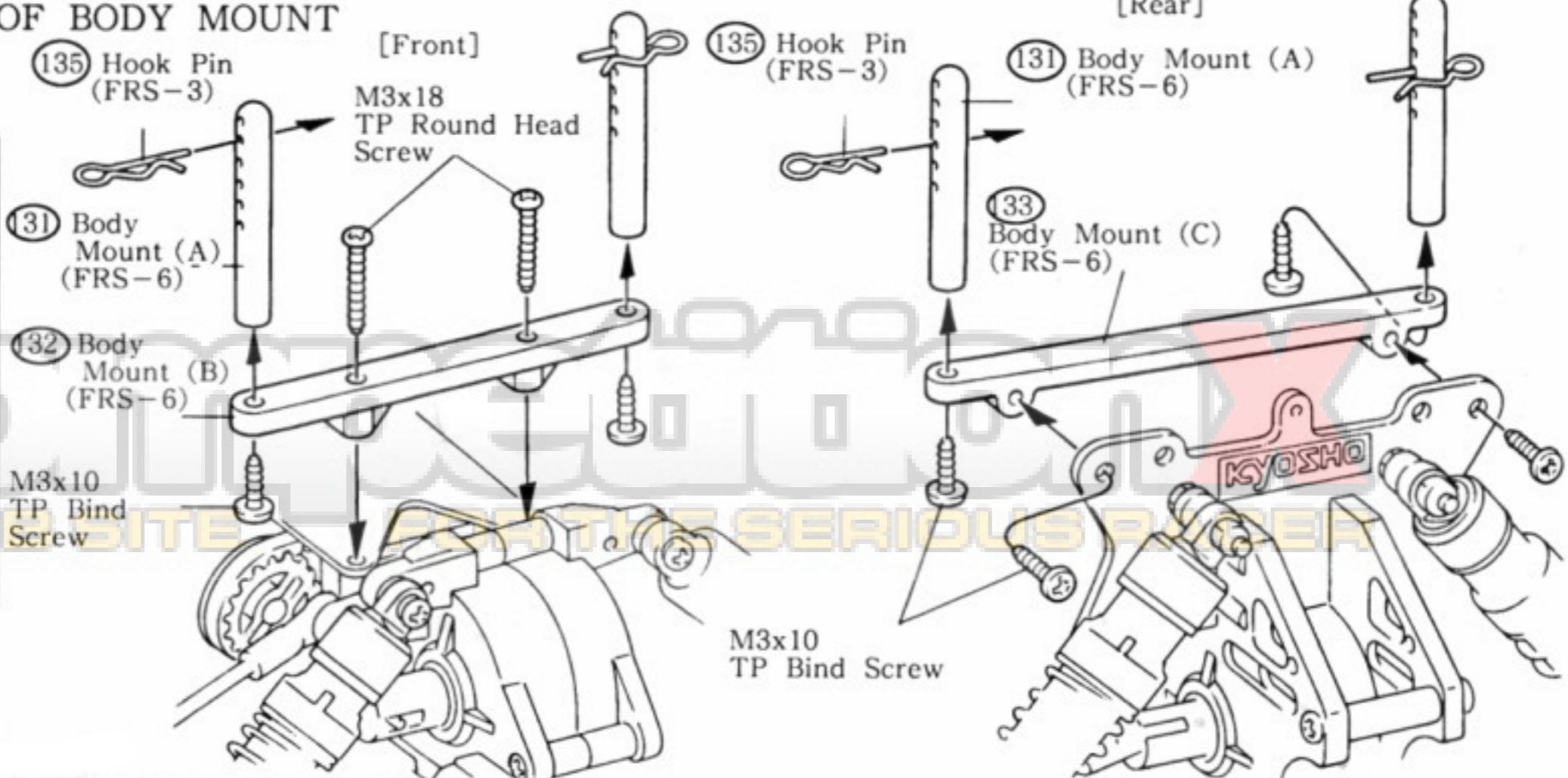

# 22 MOUNTING OF BODY

(134) Body Pin (FRS-3)

(134) Body Pins...4

(134) Body Pin (FRS-3)

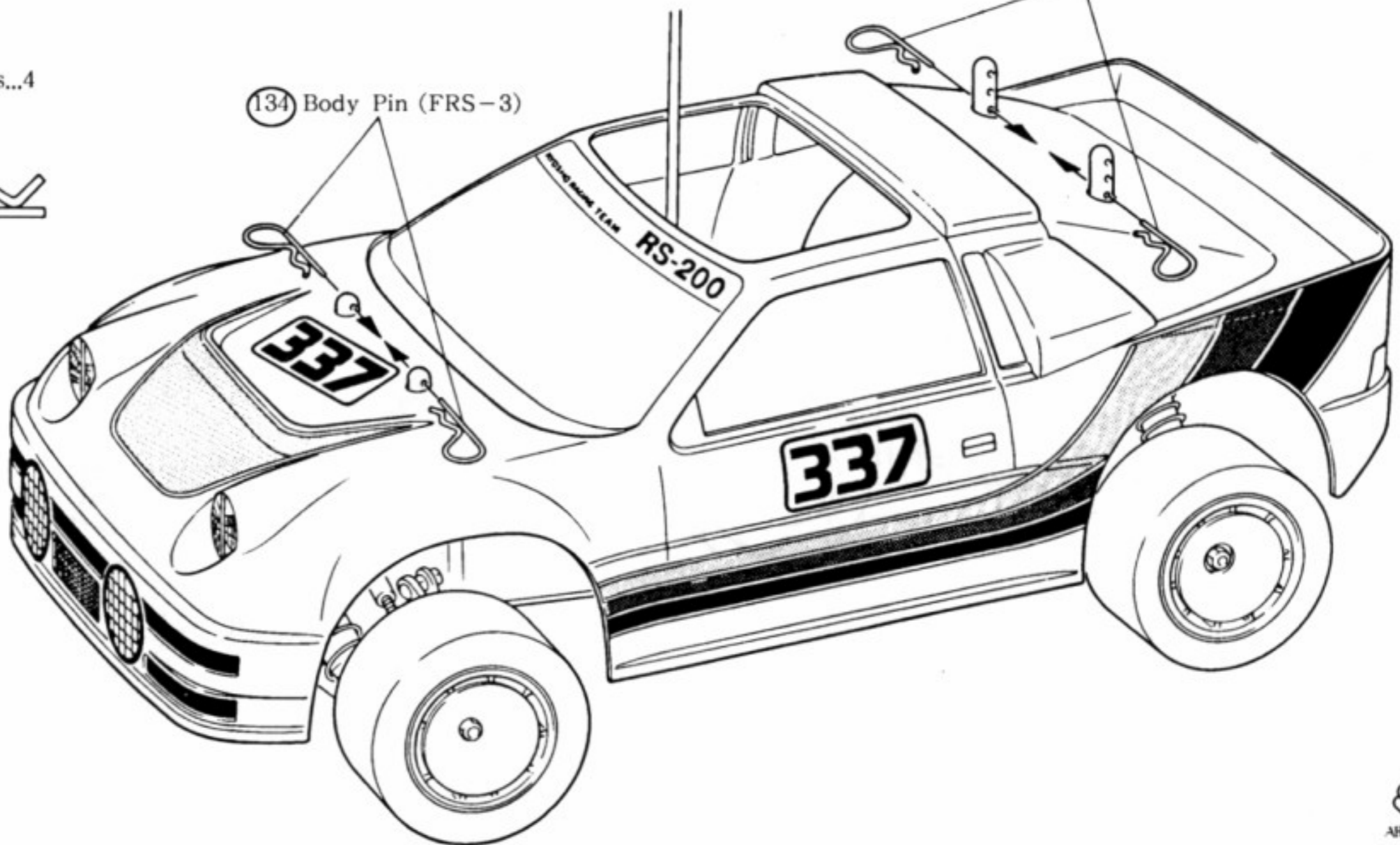

## STARTING ENGINE (1)

- The following things should be prepared to start an engine.  
4 Unit #1 (D-size) Dry cells, Glow Fuel, a can of 1 liter or 2.  
\*Gasoline or kerosene cannot be used.

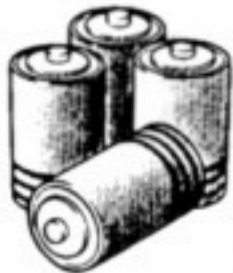

Kyosho offers an excellent R/C Model fuel "K & B Handy Fuel", which is produced under strict quality control in the U.S.A. boasting the No.1 share in the world with high purity, high quality. The fuel will allow the engine to display its full power and keep it from rust.



- Now you start the engine. Follow the procedures.

1 Fit the dry cells into the battery holder as shown.

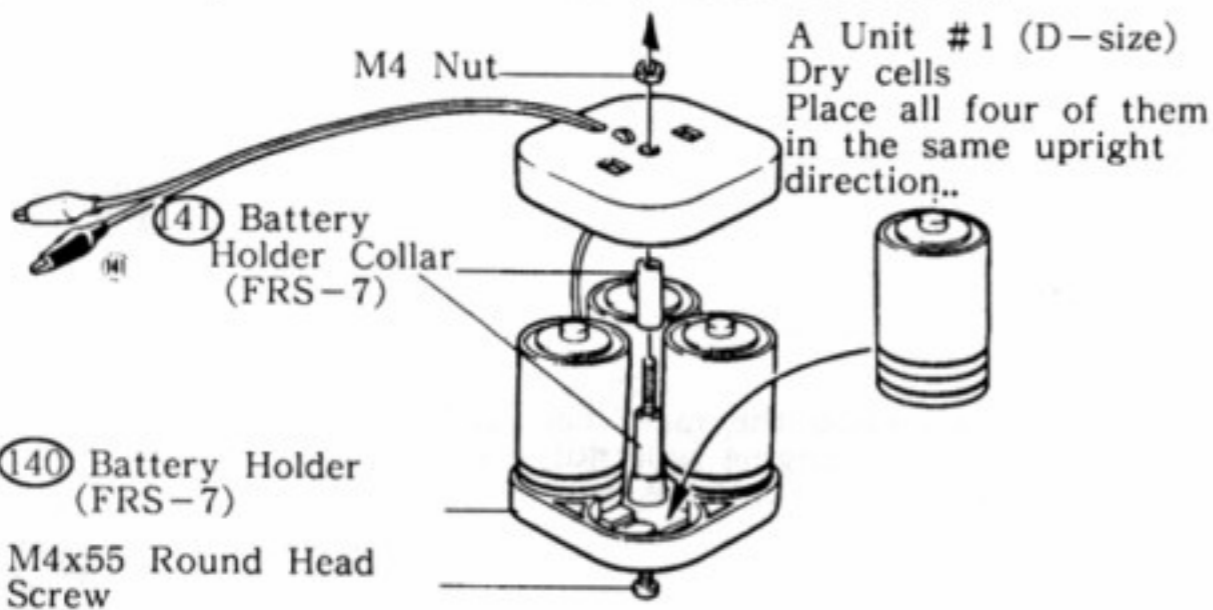

2 Set the throttle valve to idling position and check to see if the brake is engaged or not.

The clearance of the throttle valve should be about 1mm.

Adjust the setting with the throttle stop screw.

In the state of idling (Slow)

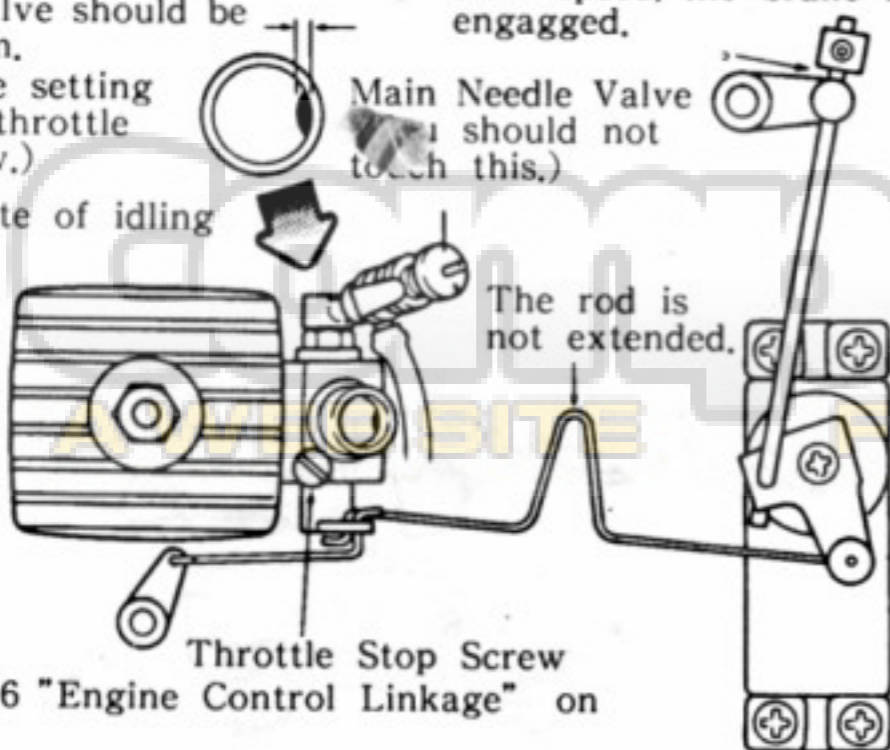

Refer to 16 "Engine Control Linkage" on page 9.

3 Fill the fuel tank with a feeder.

Screw out the cap until you see a hole.

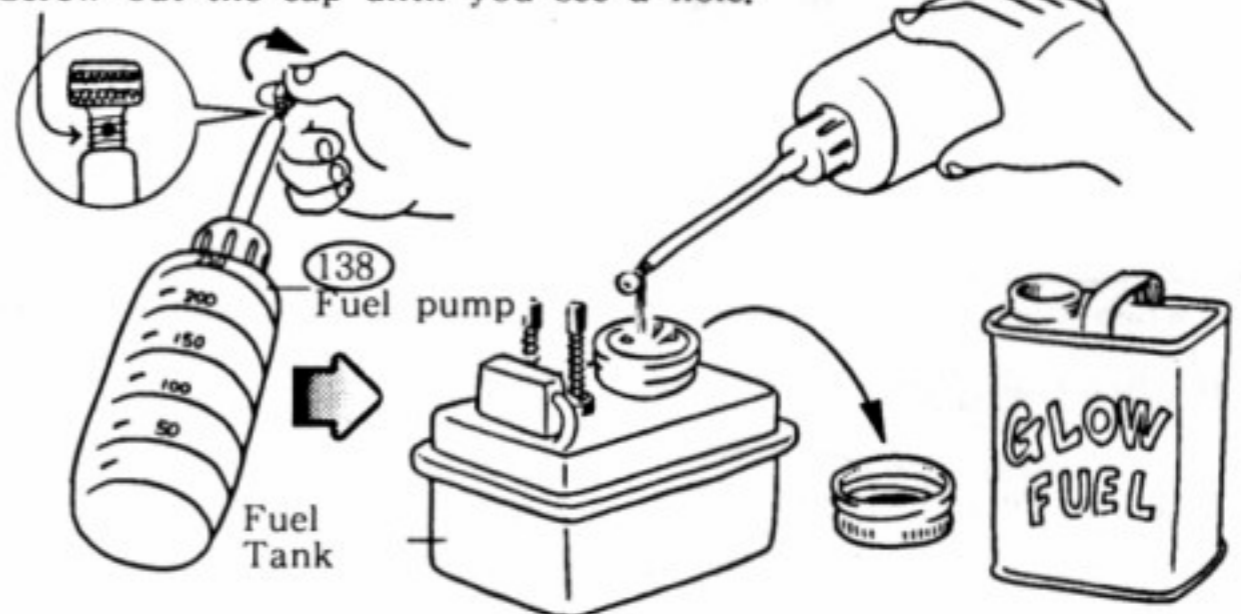

4 Press down the pump button twice or three times.

Fuel may come to this point.

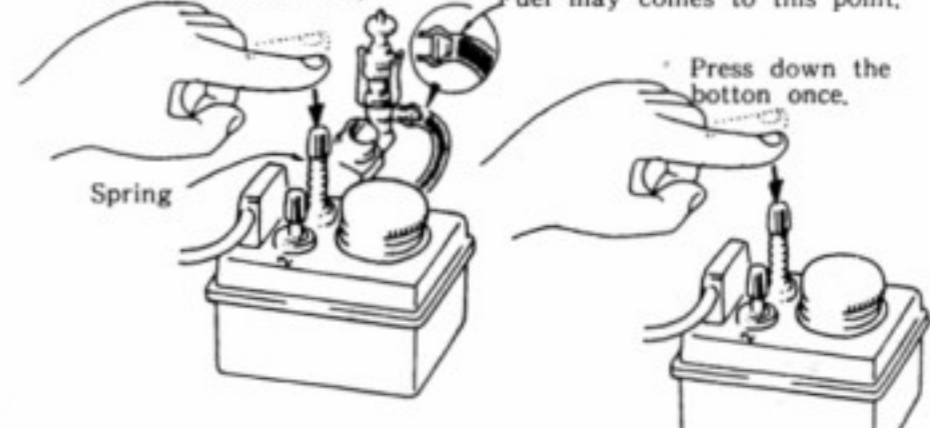

When it is hard to start, pull up the button (w/o spring) and press down twice.

Press the button (w/o spring)

5 Turn on an electric current to the plug and pull the starter quickly.

Connect the heating cord with the clip to the head of the plug.

Do not touch around here.

Clip Starter

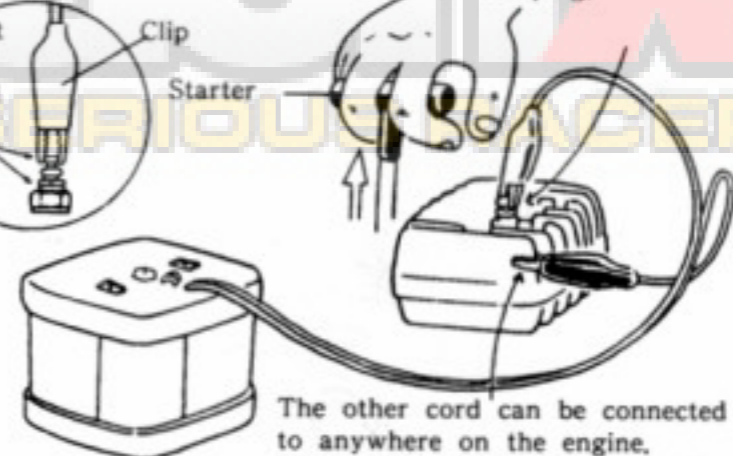

## STARTING ENGINE (2)

- 6 When the engine starts running, disconnect the clips and take a look at its idle-running. If the idle-running is too fast, the wheels may begin to rotate. If it is too slow, the engine will discontinue to run.

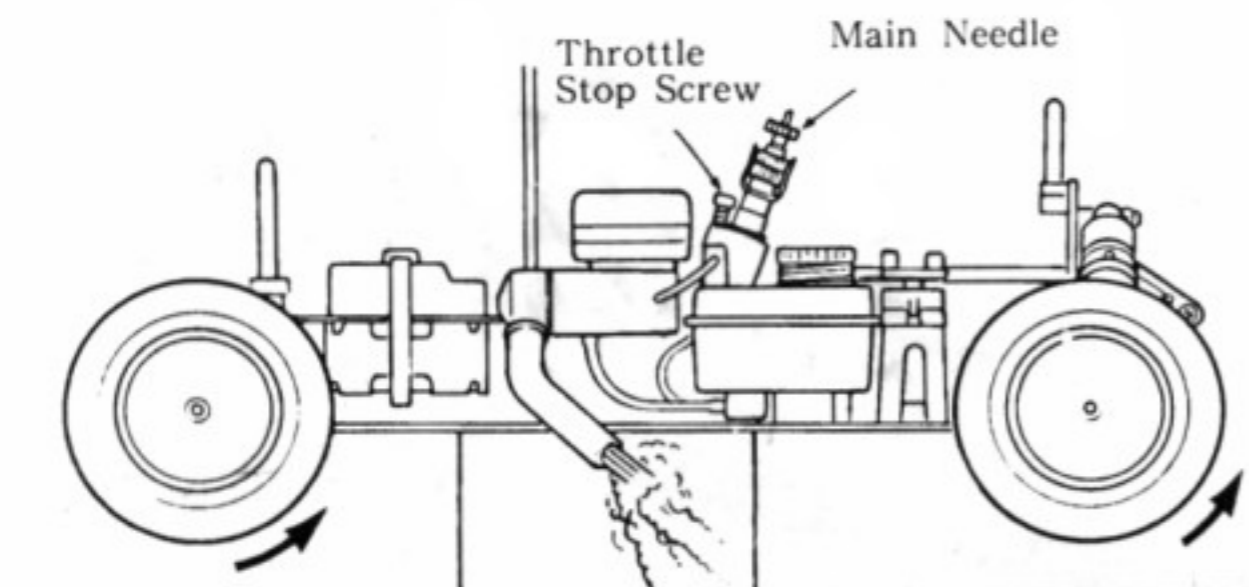

Put the model on a box or anything like that, to make it aloof from the ground.

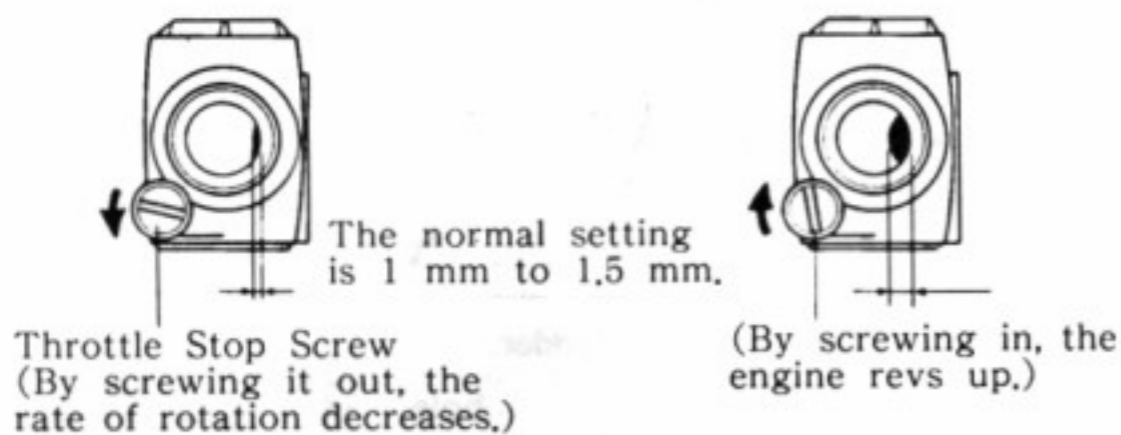

When the engine does not start...

- 7 Repeat the process 4 and 5.
- 8 In case the engine still does not start, remove the plug and electrify it. If it does not become red-hot, one of the following causes is conceivable; the battery is discharged, poor contact in the electric circuit, the filament of the plug is burnt out. Try to brush the clips in a dark place, if you see a spark, the battery is in good condition. Then you should change the plugs.

If the filament becomes red-hot, try the steps 4 and 5 again.

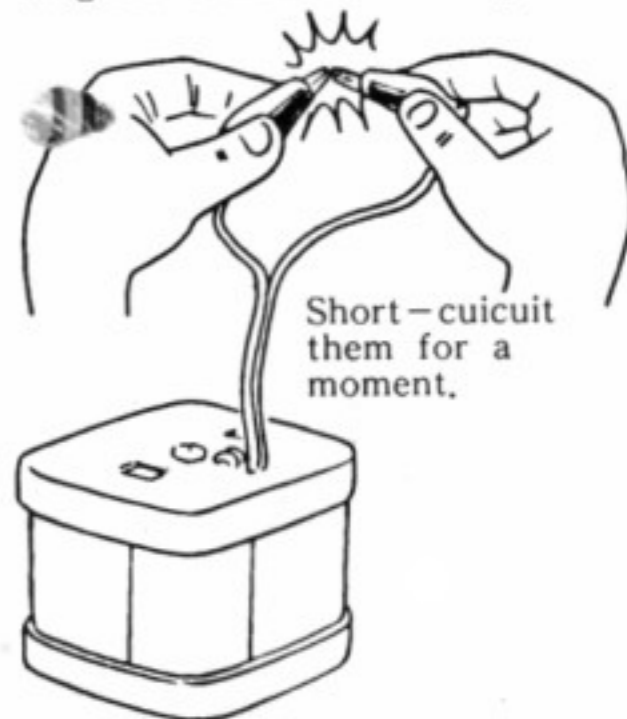

- 9 Check to see if the main needle valve is set properly. If it is out of adjustment, tighten it all the way and open it 1 1/2 turn.

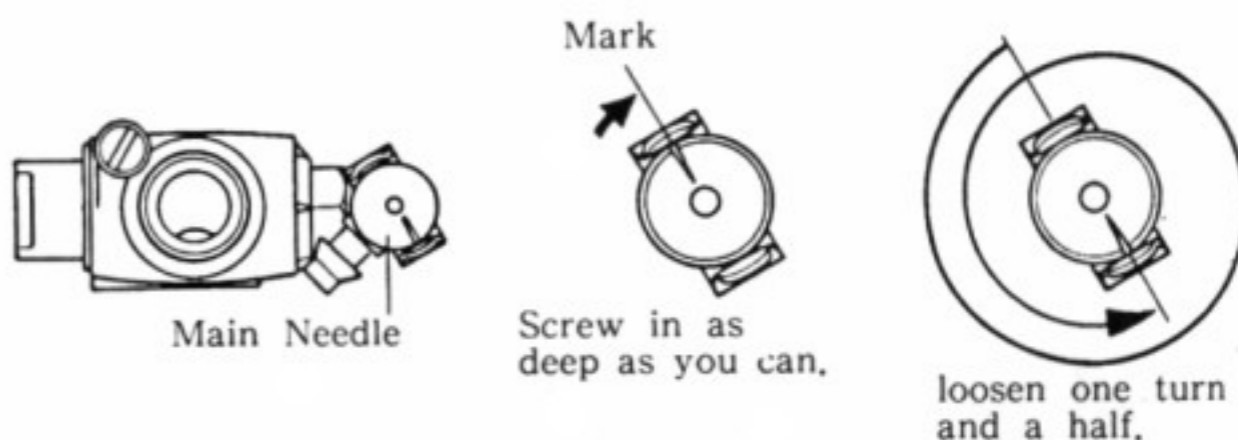

## OPERATION GUIDE (1)

When the engine is tuned correctly, the car is ready to run.

- 1 Put an air filter to the carburetor.

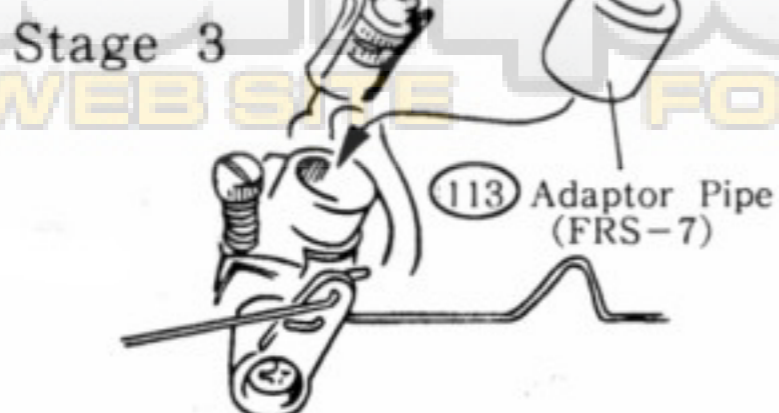
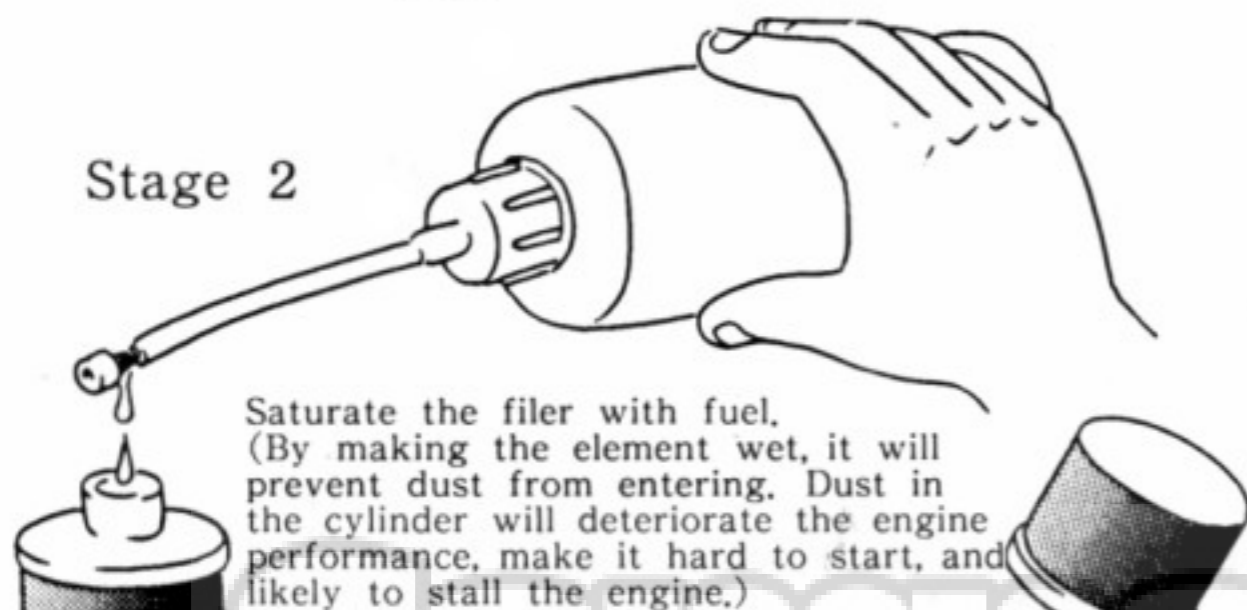
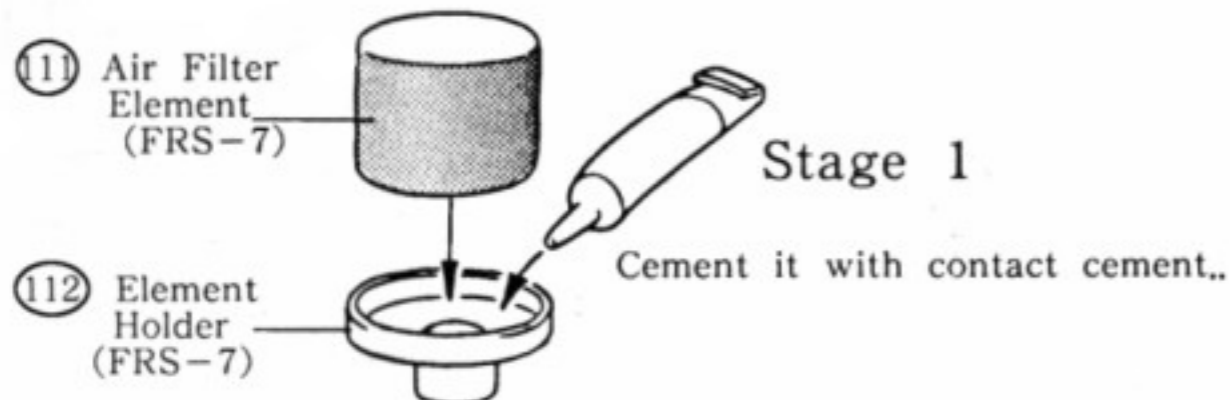

- 2 When you set the throttle lever to the high position, the engine stalls... In this case, screw out the main needle valve a little (1/3 to 1/2 turns.)

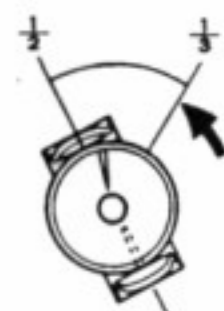

- 3 If the car runs slower than an electric car, close the main needle valve little by little (1/4 turns at a time.)



In case you close the main needle valve excessively, the engine will not rev up even when the throttle valve is set to high position. Open the needle valve 1/3 turns immediately.

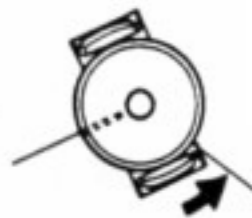

- 4 If you drive your model car furiously, it is recommended to replace 14 plain bearings on the 5 mm shaft with the ball bearings (Item No.1901). You can expect your car run faster, too, by doing so.

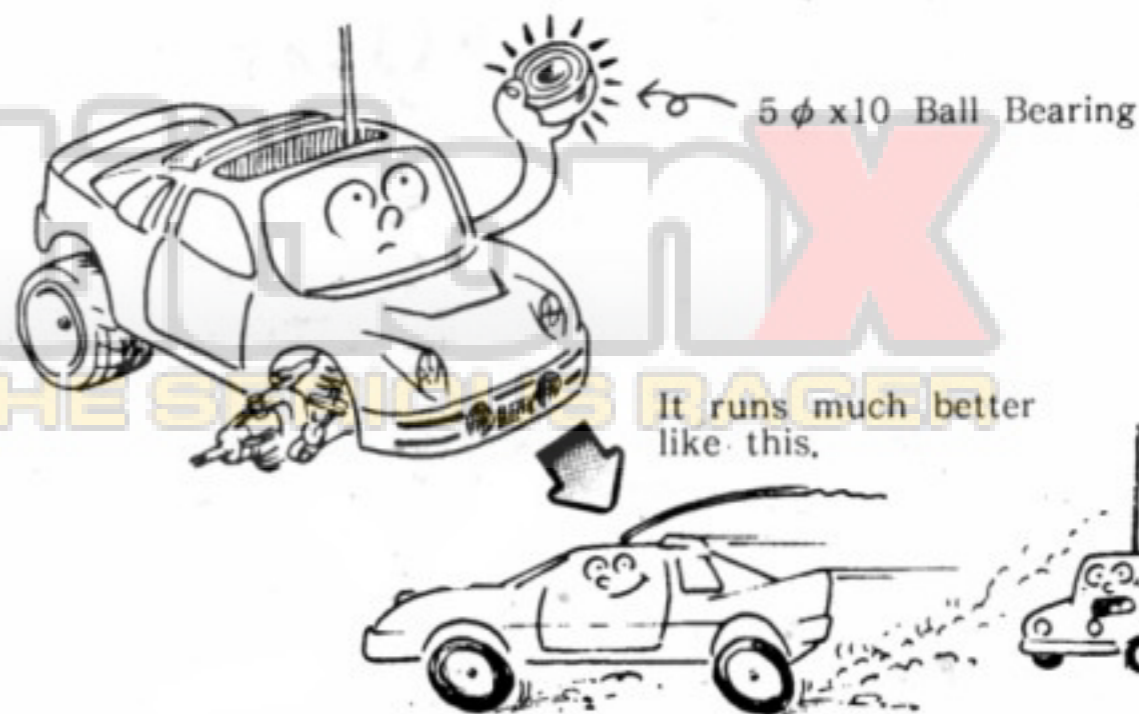

Always check the inside of the carburetor to see if there is any dust. A dusty carb means that the engine is in poor condition. Pour the fuel into the air filter and leave it until the alcohol is vaporized before refitting it.

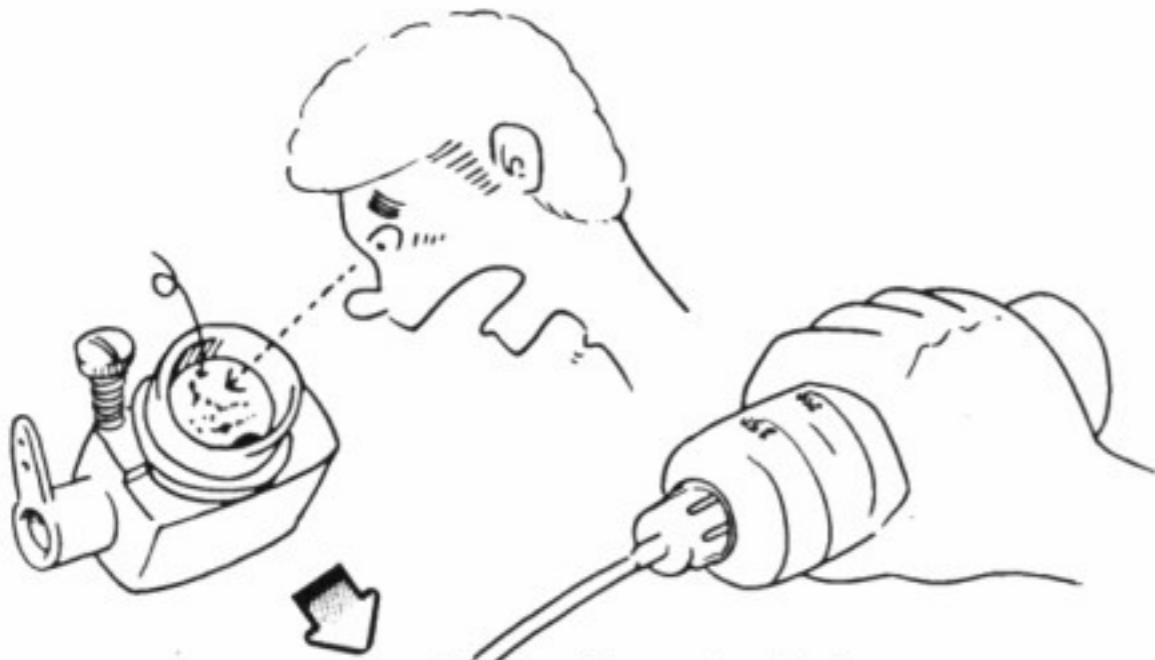

Pour the fuel.

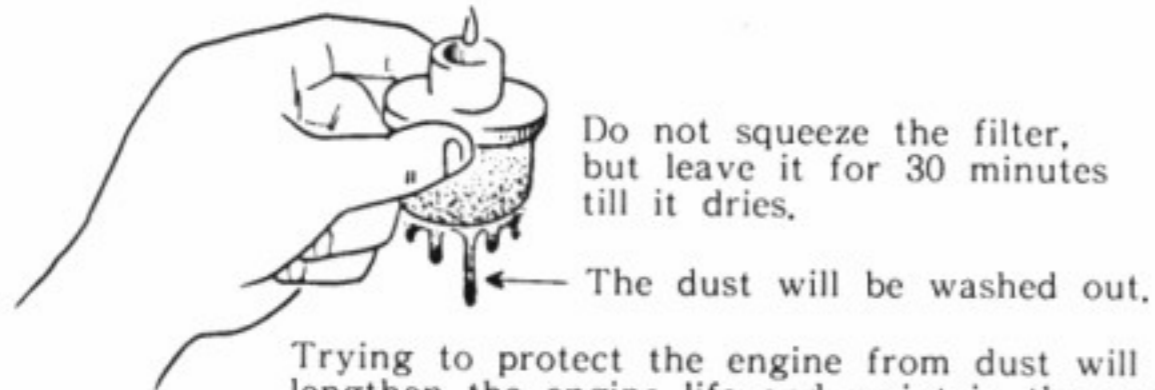

Do not squeeze the filter, but leave it for 30 minutes till it dries.

The dust will be washed out.

Trying to protect the engine from dust will lengthen the engine life and maintain the same high performance for long time.

6 When the engine stalls while running, it may be hard to start again promptly. In such a case, wait till the engine cools down sufficiently and try to start it.

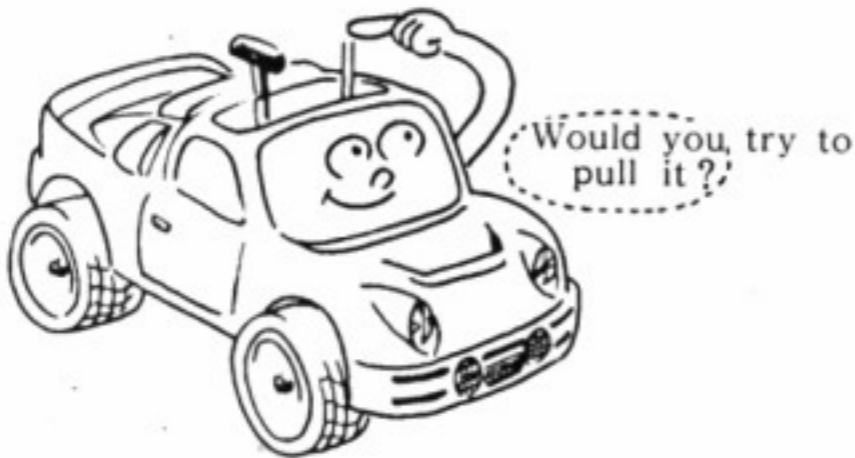
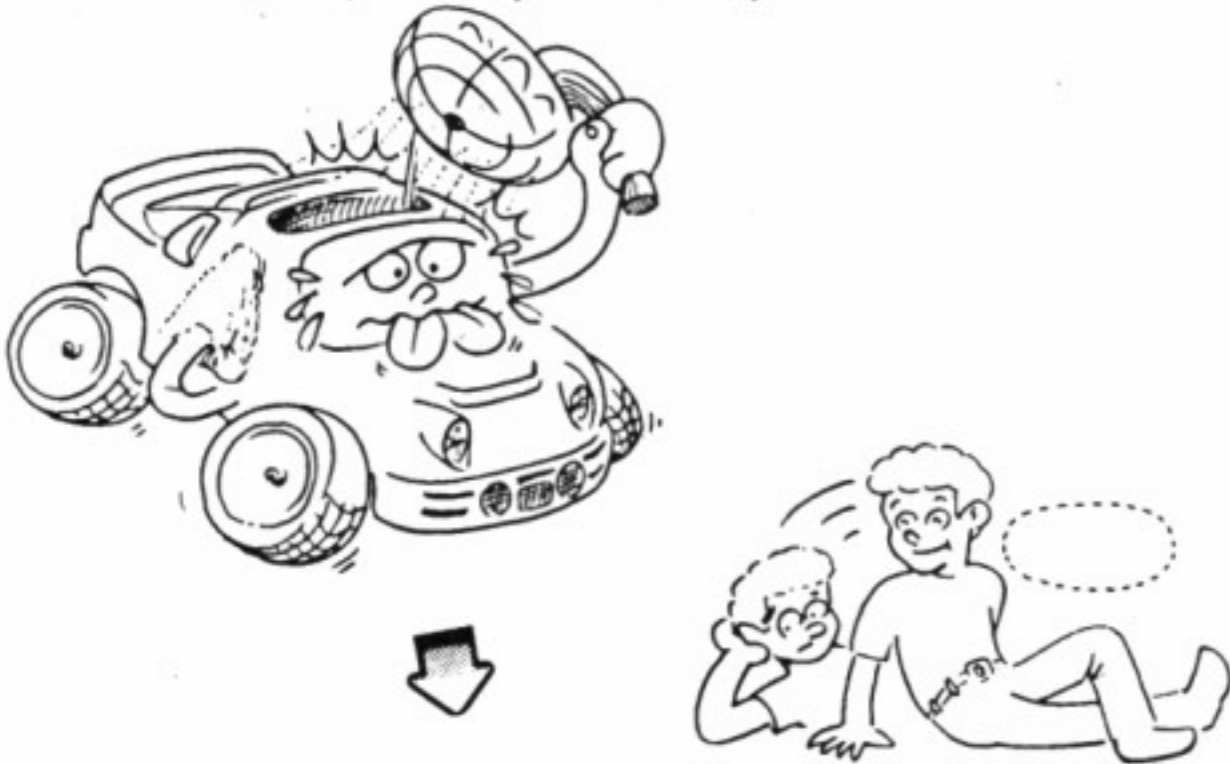

7 Oil the plate bearing portions from time to time.

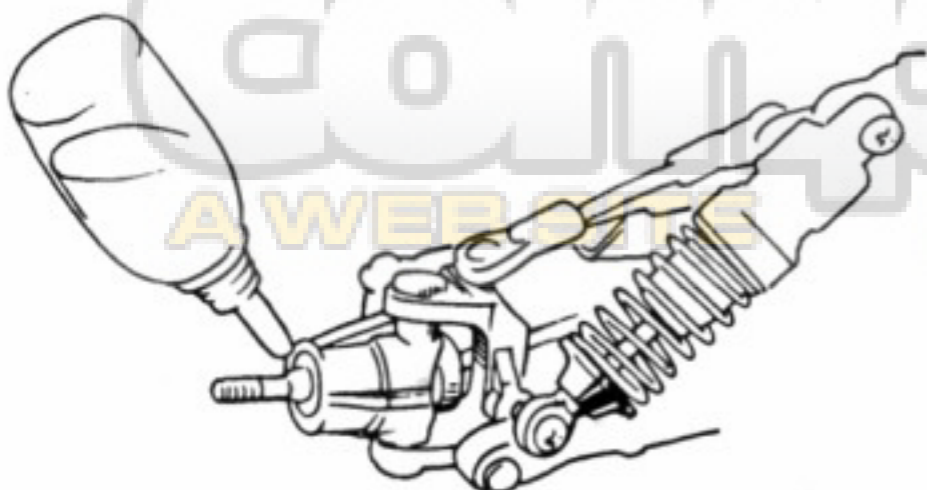

8 Overheating of the engine

The engine may be overheated when running over the places stated below, and the engine performance will deteriorate remarkably. Try not to run your car over a thickly grassy place or in a pebbly area with very bumpy surface. In a place where there is no possibility of annoying or endangering others, you may run your model without attaching a tail pipe.

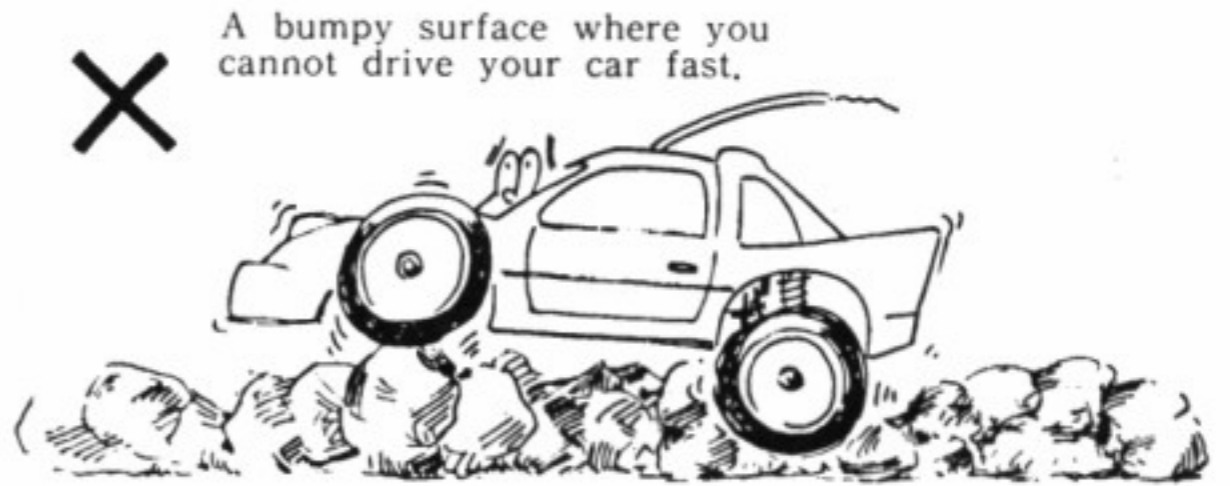

9 Span of engine life

What shortens the engine life are a dust in the engine and overheating. If you notice the engine is hard to start, or its idling is not stable, or it will not keep running without the heating cords attached to the engine, its life comes close to the end. Still you can restore an old engine by changing the piston, sleeve, and con-rod.

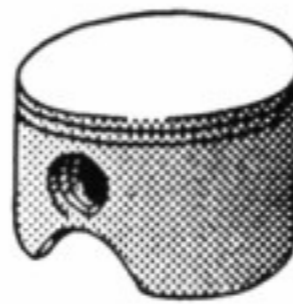

Piston

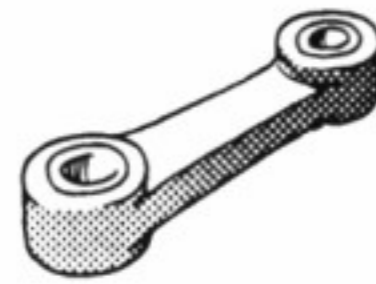

Con-rod



Sleeve

When renewing engine parts, you have to first remove the starter assembly. Disassemble it as shown below.

Stage 1

Pull up the plastic portion.

\*Never take off this E-ring.

Pull out the case rearward.

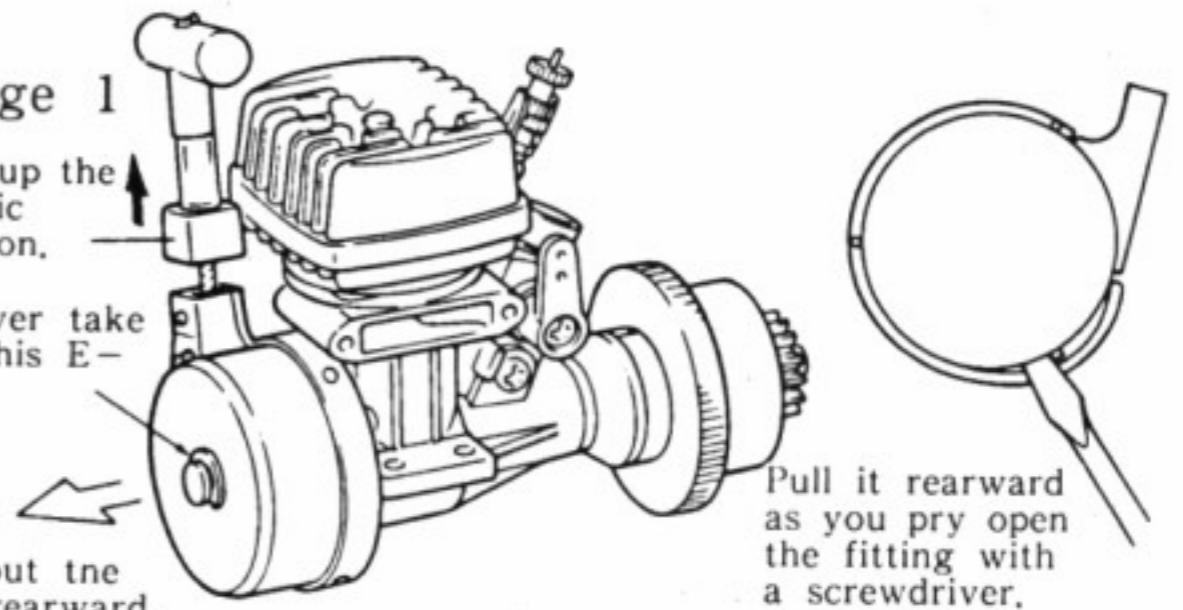

Stage 2

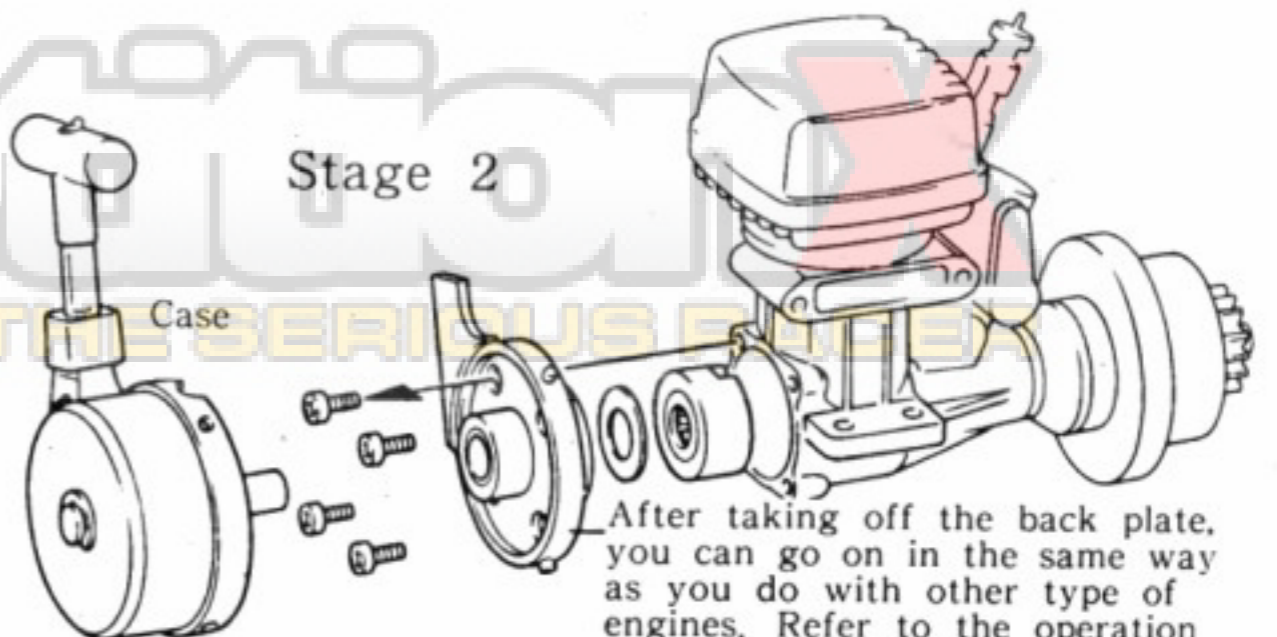

After taking off the back plate, you can go on in the same way as you do with other type of engines. Refer to the operation instruction of the OS engine.



PARTS LIST

Key #	Parts Name	Q'ty	Key #	Parts Name	Q'ty	Key #	Parts Name	Q'ty
①	Bumper	1	⑤①	Front Bulk Head (L)	1	⑨⑨	Flat Spiral Spring	1
②	Tire	4	⑤②	Front Bulk Head (R)	1	⑩①	Oneway Bearing	1
③	Wheel	4	⑤③	Front Housing	1	⑩②	Muffler	1
④	Front Wheel Shaft	2	⑤④	M2,6 Pillow Ball (Black)	2	⑩③	Muffler Cap	1
⑤	Swing Shaft	4	⑤⑤	M3 Pillow Ball (Silver)	12	⑩④	Muffler Gasket (A)	1
⑥	Drive Washer	4	⑤⑥	Ball End	12	⑩⑤	Muffler Gasket (B)	1
⑦	Joint Cap	4	⑤⑦	Ball End Rod	6	⑩⑥	Exhaust Valve	1
⑧	Final Diff. Case (A)	2	⑤⑧	Slider	1	⑩⑦	Valve Shaft	1
⑨	Final Diff. Case (B)	2	⑤⑨	Servo Saver (A)	1	⑩⑧	O Ring (P-3)	2
⑩	Bevel (A)	6	⑥①	Servo Saver (B)	1	⑩⑨	E Ring (E-2.5)	13
⑪	Bevel (B)	6	⑥②	Servo Saver Shaft	1	⑩⑩	Nozzle	1
⑫	Bevel Shaft	3	⑥③	Servo Saver Spring	1	⑩⑪	Tail Pipe	1
⑬	Final Pinion	2	⑥④	E Ring (E-5)	1	⑩⑫	Air Filter Element	1
⑭	Pin (2 φ x11)	4	⑥⑤	Center Diff. Mount (A)	1	⑩⑬	Element Holder	1
⑮	Timing Pully (A)	2	⑥⑥	Center Diff. Mount (B)	1	⑩⑭	Adaptor Pipe	1
⑯	Timing Pully (B)	2	⑥⑦	Joint Collar (Short)	2	⑩⑮	Valve Rod	1
⑰	Belt	2	⑥⑧	Joint Collar (Long)	1	⑩⑯	Throttle Rod	1
⑱	Front Counter Shaft	1	⑥⑨	Disc Plate	1	⑩⑰	Linkage Rod	2
⑲	Rear Counter Shaft	1	⑦①	Brake Pat (A)	1	⑩⑱	2 φ Linkage Guide	1
⑳	Joint	2	⑦②	Brake Pat (B)	1	⑩⑲	3 φ Linkage Guide	1
㉑	E Ring (E-4)	5	⑦③	Brake Cam Shaft	1	⑩⑳	Rod Stopper	2
㉒	Center Diff. Case (A)	1	⑦④	Brake Cam	1	⑩㉑	8 φ x14 Ball Bearing	6
㉓	Center Diff. Case (B)	1	⑦⑤	Brake Horn	1	⑩㉒	5 φ x10 Plane Bearing	14
㉔	Front Shock Case	2	⑦⑥	Rear Bulk Head (L)	1	⑩㉓	Chassis	1
㉕	Rear Shock Case	2	⑦⑦	Rear Bulk Head (R)	1	⑩㉔	Chassis Cover	1
㉖	Shock Cap	4	⑦⑧	Rear Housing	1	⑩㉕	R/C Radio Plate	1
㉗	Shock Ring	4	⑦⑨	Shock Stay	1	⑩㉖	Joint Rod	1
㉘	Spring Holder	4	⑦⑩	Rear Hub (L)	1	⑩㉗	Strap	1
㉙	Spring Spacer	4	⑦⑪	Rear Hub (R)	1	⑩㉘	Fuel Tank	1Set
㉚	Pressure Top	4	⑦⑫	5.8 φ Ball	2	⑩㉙	Fuel Pipe	3
㉛	Shock Piston	4	⑦⑬	Servo Mount	4	⑩㉚	Antenna Holder	1
㉜	Front Shock Shaft	2	⑦⑭	Radio Plate Post (A)	1	⑩㉛	Antenna	1
㉝	Rear Shock Shaft	2	⑦⑮	Radio Plate Post (B)	1	⑩㉜	Body Mount (A)	4
㉞	Shock End	4	⑦⑯	Engine Mount	2	⑩㉝	Body Mount (B)	1
㉟	Front Shock Spring	2	⑦⑰	Clutch Bell	1	⑩㉞	Body Mount (C)	1
㊱	Rear Shock Spring	2	⑦⑱	Clutch Shoe	2	⑩㉟	Body Pin	4
㊲	Rear Wheel Shaft	2	⑦⑲	Clutch Spring	1	⑩㊱	Hook Pin	4
㊳	Knuckle Arm (R)	1	⑦⑳	Pilot Shaft	1	⑩㊲	Plug Wrench	1
㊴	Knuckle Arm (L)	1	⑦㉑	Flywheel	1	⑩㊳	Body (Ford RS-200)	1
㊵	King Pin	4	⑦㉒	Flywheel Spacer	1	⑩㊴	Fuel Pump	1
㊶	Front Hub (R)	1	⑦㉓	Clutch Bearing Case	1	⑩㊵	Shock Oil	1
㊷	Front Hub (L)	1	⑦㉔	Clutch Roller	6	⑩㊶	Battery Holder	1Set
㊸	Front Sus. Arm	2	⑦㉕	E Ring (E-7)	1	⑩㊷	Battery Holder collar	2
㊹	Rear Sus. Arm	2	⑦㉖	Starter Holder	1	⑩㊸	Decal	1
㊺	Sus. Shaft (A) (Silver)	2	⑦㉗	Stater Case	1	⑩㊹	Hex Key (1,5)	1
㊻	Sus. Shaft (B) (Black)	2	⑦㉘	Starter Grip	1	⑩㊺	Hex Key (2)	1
㊼	Sus. Shaft (C)	2	⑦㉙	Starter Guide	1	⑩㊻	Shock Bush	4
㊽	Sus Shaft (D)	2	⑦㉚	Stater Pulley	1	⑩㊼	Front Sus. Plate	1
㊾	Shaft Holder	1	⑦㉛	Starter Rope	1	⑩㊽	E Ring (E-3)	1

**PURCHASABLE PARTS FOR YOUR KIT**

You can purchase replacement optional parts for your kit. All of the part identified by key number are usually not available singularly, but we offer these parts in convenient parts "packs" which can be purchased separately. To figure out which parts pack you need, find the key number for that part with the manual.

Then consult out part pack guide below. When referring to the parts you need, always use the Parts Pack Number. For example, if you need a King Pin (Key #40) ask your dealer for Kyosho Part Pack OT-4 (King Pin).

No.	Parts Name	Key No. & Q'ty
OT-4	King Pin	④×4
OT-5	Joint	⑦×2
OT-6	Swing Shaft	⑨×2
OT-11	Sus. Shaft	⑬⑭⑮⑯×2
OT-16	Knuckle Arm	⑳×1
OT-17	Front Shaft	④×2
OT-18	Rear Shaft	⑰×2
OT-19	Drive Washer	⑥×4
OT-28	Diff. Gear Set	⑫×2 ⑩⑪×4
OT-31	M3 Pillow Ball	㉑×10
OT-32	5.8 φ Ball	㉒×10
OT-35	Upper Rod Set	㉓×4 ㉔×8
OT-36	M2,6 Pillow Ball	㉕×10
OT-39	E Ring (E2-5)	㉖×10
OT-42	Servo Saver Set	㉗㉘㉙㉚㉛×1
OT-45	Rear Hub	㉜㉝×1
OT-55	Front Hub Set	㉞㉟×1
OT-69	Sus. Arm Set	㊱㊲×2
EP-22	Hook Pin	㊳×5
1911	8 φ x14 Bearing	㊴×2
1889	Body Pin	㊵×5
W-5053	Tire (Radial Pattern)	②×2
AB-12	Air Filter	㊶㊷㊸×1
AB-14	Pilot Shaft (For OS)	㊹㊺㊻×1
AB-15	Clutch Shoe	㊼×2
AB-16	Clutch Bell	㊽×1
AB-17	Clutch Spring	㊾×4
EF-39	NiCd Strap	㊿×6
LD-70	Clutch Bearing	㊿×1 ⑩×6
SD-79	Antenna Pipe	㊿×5
KC-20	E Ring (E4)	⑩×5
FD-1	Bumper	①×1
FD-2	Wheel	③×4
FD-3	Belt	⑩×1
FD-4	Final Diff. Case	①②×1
FD-5	Center Diff. Case	⑲⑳×1
FD-6	Final Pinion	⑬×1
FD-7	Timing Pully	⑬⑭⑮×1 ⑯×2
FD-8	Front Counter Shaft	⑰×1
FD-9	Rear Counter Shaft	⑱×1
FD-10	Joint	㉑×2
FD-11	Shaft Holder	④×1
FD-12	Front Bulk Head	㉒㉓㉔×1
FD-13	Slider Set	㉕㉖㉗×1
FD-14	Center Diff. Mount	㉘㉙×1
FD-15	Chassis Set	㉚㉛㉜×1 ㉝×2

No.	Parts Name	Key No. & Q'ty
FD-16	Brake Parts	⑰⑱⑲×1
FD-17	Servo Mount Set	㉑㉒㉓㉔×1 ㉕×4
FD-18	Rear Bulk Head	㉖㉗㉘×1
FD-19	Rear Shock Stay	㉙×1
FD-20	Engine Mount	㉚×2
FD-21	Flywheel Set	㉛㉜×1
FD-22	Starter Holder	㉝×1
FD-23	Starter Assembly	㉞㉟㊱㊲㊳×1
FD-24	Oneway Assembly	㊴×1
FD-25	Muffler Assembly	㊵㊶㊷㊸㊹㊺㊻㊼㊽×1 ㊾×2
FD-26	5 φ x10 Plane Bearing	㊿×10
FD-27	Chassis	①×1
FD-28	Fuel Tank	②×1
FD-29	Fuel Tube	③×2
FD-30	Battery Holder	④⑤×1
FD-31	Screw Set	
FD-32	Body Mount	⑥⑦×1 ⑧×4
FD-33	Tail Pipe	⑨×1
FD-34	Body (RS-200)	⑩×1
FD-35	Decal (RS-200)	⑪×1
FD-36	Linkage set	⑫⑬⑭⑮×1 ⑯⑰×2
FD-37	Black Shock (S)	㉑㉒㉓㉔㉕㉖㉗㉘㉙㉚×2
FD-38	Black Shock (L)	㉛㉜㉝㉞㉟㊱㊲㊳㊴㊵×2

**OPTIONAL PARTS**

KC-18	3 φ Stopper	Steel
SD-53	Clutch Bell (12T)	Steel
SD-54	Clutch Bell (13T)	Steel
SD-55	Clutch Bell (14T)	
SD-60	Clutch Bearing	
OT-99	Wing Stay	
OT-107	Wing	
W-5001	Pressure Shock (S)	
W-5002	Pressure Shock (L)	
W-5003	Adjustable Shock (S)	Easy adjustable damping force
W-5004	Adjustable Shock (L)	Easy adjustable damping force
W-5005	Special Rod Set	One touch adjustable
W-5031	Low Profile Tire (Hard)	For Hard Truck
W-5032	Low Profile Tire (Soft)	For Soft Truck
W-5061	Universal Swing Shaft	For smooth drive
1901	5 φ x10 Bearing	2 pcs.
1953	Silicon Oil (S)	Soft
1954	Silicon Oil (M)	Medium
1955	Silicon Oil (H)	Hard
AB-13	Pilot Shaft	For Enya

**The Super Hobby**

A WEB SITE FOR THE SUPER RACER

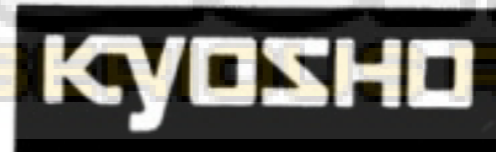

This products is not to be sold in the United States. If you have purchased this product in the United States, please contact Tom Miller at Kyosho U.S.A. phone number (217) 398-3630.

PRINTED IN JAPAN

\* WHEN STARTING AN ENGINE \*

Even if the starter rope is much more resistable to pull up, it does not mean that the engine is out of order. But excessive amount of fuel is fed into the cylinder. This called a state of "flooded".

Remove the glow plug with a plug wrench and pull up the starter rope ten to twenty times with quick pulling to discharge the excessive fuel.

